

Grizzly **Industrial, Inc.**®

MODEL G0644 15" OPEN-END WIDE BELT SANDER OWNER'S MANUAL



COPYRIGHT © NOVEMBER, 2007 BY GRIZZLY INDUSTRIAL, INC.
**WARNING: NO PORTION OF THIS MANUAL MAY BE REPRODUCED IN ANY SHAPE
OR FORM WITHOUT THE WRITTEN APPROVAL OF GRIZZLY INDUSTRIAL, INC.**

#TS9790 PRINTED IN TAIWAN



WARNING!

This manual provides critical safety instructions on the proper setup, operation, maintenance and service of this machine/equipment.

Failure to read, understand and follow the instructions given in this manual may result in serious personal injury, including amputation, electrocution or death.

The owner of this machine/equipment is solely responsible for its safe use. This responsibility includes but is not limited to proper installation in a safe environment, personnel training and usage authorization, proper inspection and maintenance, manual availability and comprehension, application of safety devices, blade/cutter integrity, and the usage of personal protective equipment.

The manufacturer will not be held liable for injury or property damage from negligence, improper training, machine modifications or misuse.



WARNING!

Some dust created by power sanding, sawing, grinding, drilling, and other construction activities contains chemicals known to the State of California to cause cancer, birth defects or other reproductive harm. Some examples of these chemicals are:

- **Lead from lead-based paints.**
- **Crystalline silica from bricks, cement and other masonry products.**
- **Arsenic and chromium from chemically-treated lumber.**

Your risk from these exposures varies, depending on how often you do this type of work. To reduce your exposure to these chemicals: Work in a well ventilated area, and work with approved safety equipment, such as those dust masks that are specially designed to filter out microscopic particles.

Table of Contents

INTRODUCTION	2	SECTION 5: ACCESSORIES	26
Foreword	2	SECTION 6: MAINTENANCE	27
Contact Info	2	Schedule	27
Machine Data Sheet	3	Cleaning	27
Basic Identification	5	Lubrication	27
Operation Control Identification	6	Air Regulator/Filter	28
SECTION 1: SAFETY	7	SECTION 7: SERVICE	29
Safety Instructions for Machinery	7	Troubleshooting	29
Safety Instructions for Wide Belt Sanders	9	Conveyor Belt Tensioning	31
SECTION 2: CIRCUIT REQUIREMENTS	10	Conveyor Belt Tracking	32
220V Operation	10	Gib Adjustment	32
SECTION 3: SETUP	11	Sanding Drum & Conveyor Parallelism	33
Setup Safety	11	Air Pressure Safety Switch	34
Items Needed for Setup	11	Adjusting Depth Of Cut Safety Bar	34
Unpacking	11	Adjusting Pressure Rollers	35
Inventory	12	Replacing Conveyor Belt	36
Hardware Recognition Chart	13	Electrical Wiring Overview	38
Clean Up	14	Electrical Box & Control Panel Wiring Diagram	39
Site Considerations	14	Electrical Components	40
Mounting to Shop Floor	15	Air System Diagram	42
Moving & Assembling Sander	15	Parts Breakdown	43
Dust Collection	17	Label Placement & List	46
Test Run	18	WARRANTY AND RETURNS	49
Recommended Adjustments	19		
SECTION 4: OPERATIONS	20		
Operation Safety	20		
Sanding Overview	20		
Choosing Sandpaper	21		
Sanding Belt Replacement	21		
Conveyor Speed	23		
Depth of Cut	23		
Sanding Tips	24		
Sanding Belt Oscillation Rate	25		

INTRODUCTION

Foreword

We are proud to offer the Model G0644 15" Open-End Wide Belt Sander. The open end design of the Model G0644 can sand stock up to 30" wide. Depth of cut is precisely controlled with the elevation handwheel and scale, and the feed rate is set with the conveyor variable speed dial and monitored with the amp load meter. For quality sanding finish, the pneumatic system automatically oscillates the sanding belt from side-to-side.

This machine is part of a growing Grizzly family of fine woodworking machinery. When used according to the guidelines set forth in this manual, you can expect years of trouble-free, enjoyable operation and proof of Grizzly's commitment to customer satisfaction.

The specifications, drawings, and photographs illustrated in this manual represent the Model G0644 when the manual was prepared. However, owing to Grizzly's policy of continuous improvement, changes may be made at any time with no obligation on the part of Grizzly.

For your convenience, we always keep current Grizzly manuals available on our website at **www.grizzly.com**. Any updates to your machine will be reflected in these manuals as soon as they are complete. Visit our site often to check for the latest updates to this manual!

Contact Info

If you have any comments regarding this manual, please write to us at the address below:

Grizzly Industrial, Inc.
c/o Technical Documentation Manager
P.O. Box 2069
Bellingham, WA 98227-2069
Email: manuals@grizzly.com

We stand behind our machines. If you have any service questions or parts requests, please call or write us at the location listed below.

Grizzly Industrial, Inc.
1203 Lycoming Mall Circle
Muncy, PA 17756
Phone: (570) 546-9663
Fax: (800) 438-5901
E-Mail: techsupport@grizzly.com
Web Site: <http://www.grizzly.com>





MACHINE DATA SHEET

Customer Service #: (570) 546-9663 • To Order Call: (800) 523-4777 • Fax #: (800) 438-5901

MODEL G0644 15" OPEN-END WIDE BELT SANDER

Product Dimensions:

Weight 418 lbs.
 Length/Width/Height 40" x 24" x 62½"
 Foot Print (Length/Width) 22½" x 17½"

Shipping Dimensions:

Box 1

Type..... Cardboard
 Content..... Machine
 Weight 348 lbs.
 Length/Width/Height 44" x 26" x 39"

Box 2

Type..... Cardboard
 Content..... Stand
 Weight 70 lbs.
 Length/Width/Height 19" x 24" x 26"

Electrical:

Switch..... Magnetic Switch with Thermal Overload
 Switch Voltage 220V
 Cord Length 6½ ft.
 Cord Gauge 14 gauge
 Recommended Circuit Size 20A
 Plug..... No

Motors:

Sanding Drum

Type..... TEFC Capacitor Start Induction
 Horsepower 3 HP
 Voltage 220VAC
 Phase Single
 Amps 14A
 Speed 1725 RPM
 Cycle..... 60 Hz
 Number Of Speeds..... 1
 Power Transfer..... Direct Drive
 Bearings Sealed and Lubricated



Conveyor Feed

Type.....	Direct Current Variable Speed
Horsepower	1/10 HP
Voltage	220VDC
Phase	Single
Amps	1A
Number of Speeds	Variable
Speed	10–34 RPM
Cycle.....	60 Hz
Power Transfer.....	Gearbox
Bearings	Sealed and Lubricated

Main Specifications

Operation Information

Number of Sanding Drums.....	1
Maximum Board Width.....	15"
Minimum Board Width.....	2"
Maximum Board Thickness.....	6"
Minimum Board Thickness.....	1/4"
Minimum Board Length.....	6"
Sanding Drum Speed.....	1850 FPM
Sanding Drum Diameter.....	4"
Conveyor Feed Rate.....	5–17 FPM
Sandpaper Length.....	48"
Sandpaper Width.....	16"

Sanding Drum Information

Drum Type.....	Rubber
Drum Diameter.....	4"

Construction Information

Conveyor Belt.....	Heavy-Duty Rubber
Body	Steel
Paint	Powder Coat

Other Information

Number of Pressure Rollers.....	2
Pressure Roller Type.....	Steel
Pressure Roller Diameter.....	3/4"
Number of Dust Ports.....	1
Dust Port Size	4"
Mobile Base.....	G7315 with G8685 Extension

Other Specifications:

Country of Origin.....	Taiwan
Warranty.....	1 Year
Serial Number Location	ID Label on Front
Assembly Time	1 Hour
Required Air Pressure.....	57 PSI

Features:

- Variable Speed Conveyor Feed
- Pneumatic Belt Tracking
- Emergency Brake System
- Spring Belt Tensioning System
- Amp Load Meter



Basic Identification

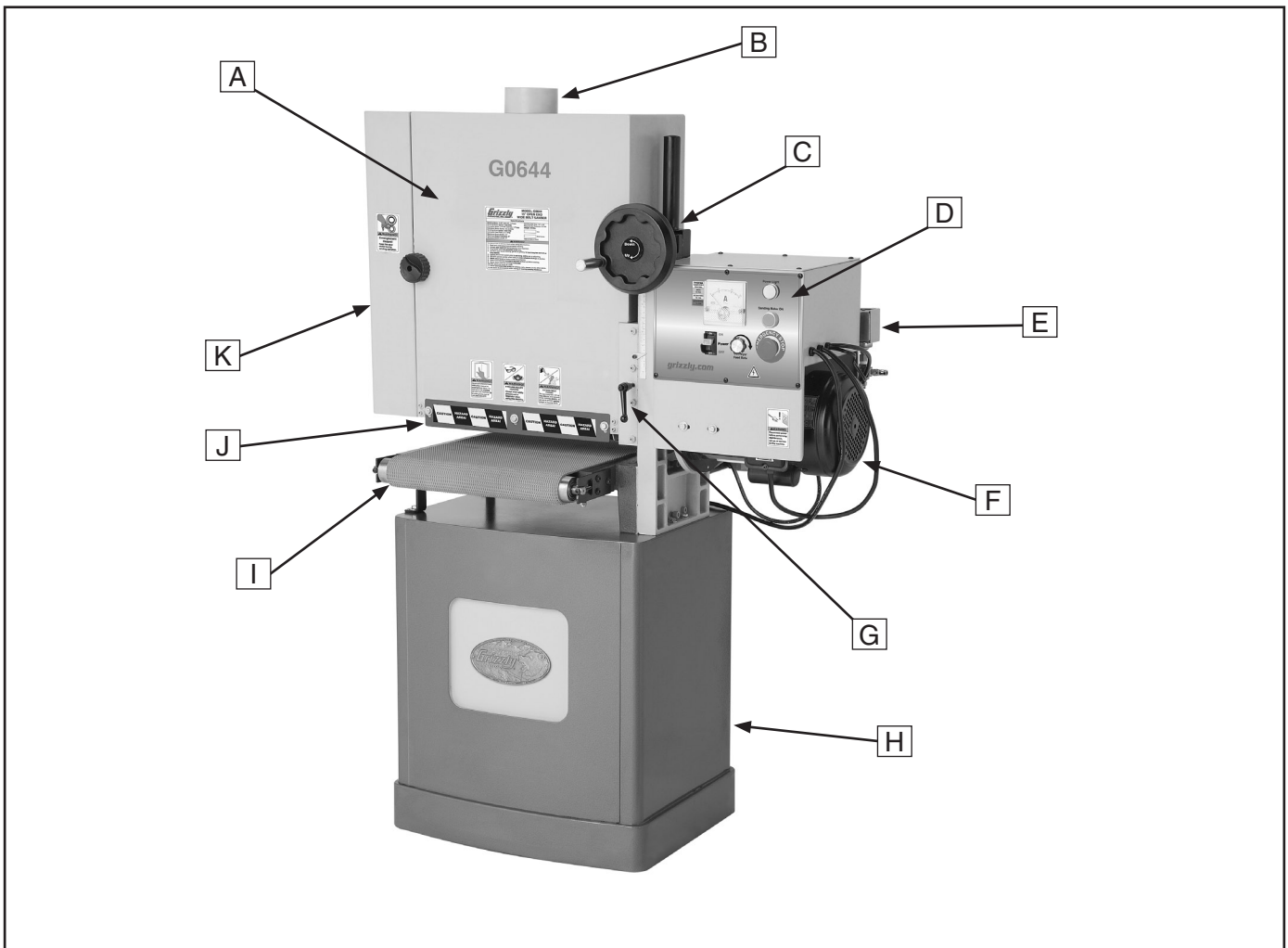

Figure 1. Model G0644 identification.

- | | |
|--|------------------------------------|
| A. Sanding Cabinet | G. Elevation Lock Lever |
| B. Dust Port 4" | H. Cabinet Stand |
| C. Elevation Handwheel | I. Conveyor |
| D. Control Panel & Electrical Box | J. Depth Of Cut Safety Bar |
| E. Air Regulator | K. Sanding Belt Access Door |
| F. Motor 3 HP | |



Operation Control Identification

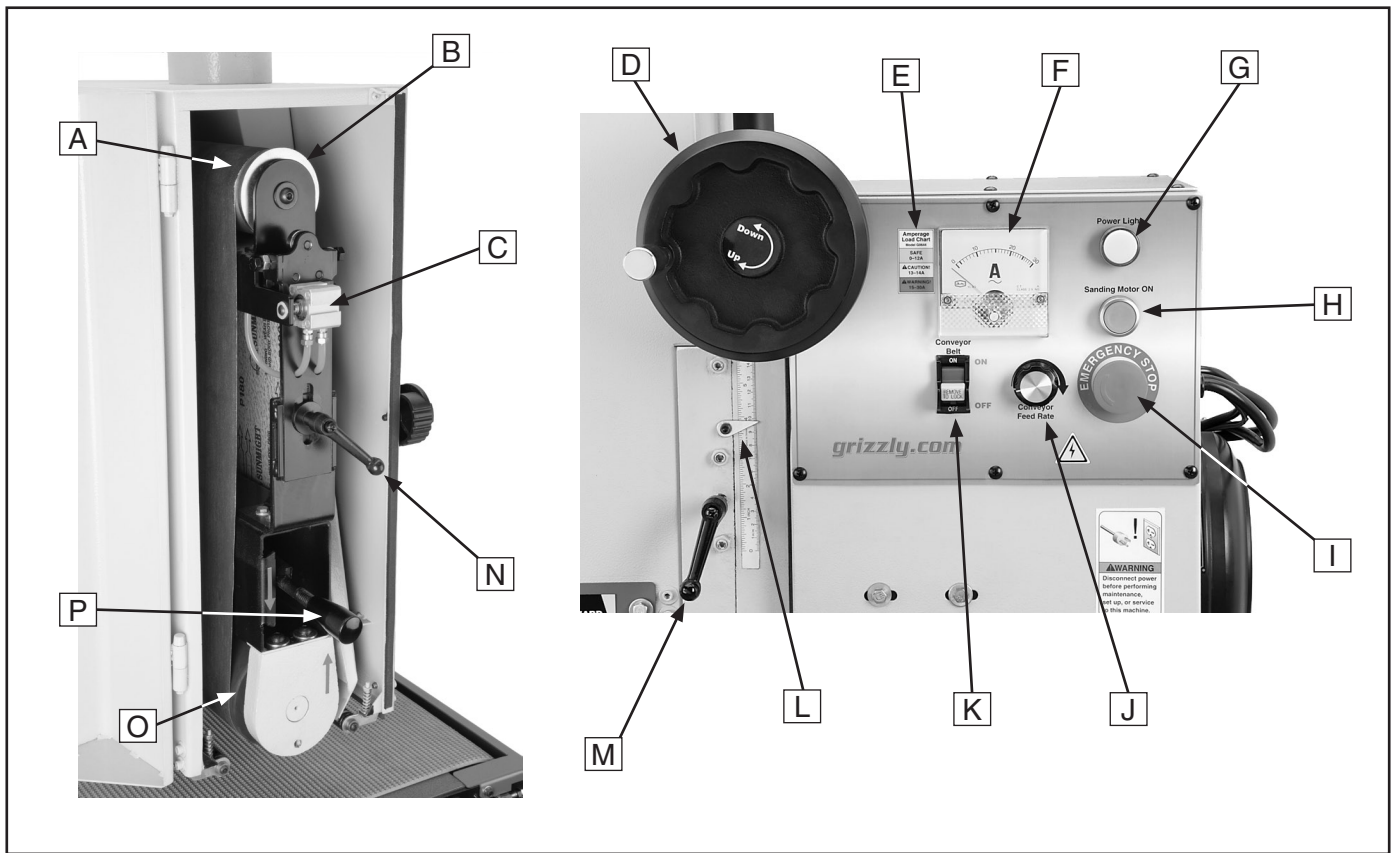

Figure 2. Model G0644 operation control identification.

- | | |
|------------------------------|---|
| A. Upper Sanding Roller | I. Emergency Stop Button |
| B. Left Oscillation Disc | J. Conveyor Speed Dial |
| C. Oscillation Control Valve | K. Conveyor ON/OFF Switch w/Disabling Key |
| D. Elevation Handwheel | L. Elevation Scale & Pointer |
| E. Amperage Load Chart | M. Elevation Lock Lever |
| F. Amp Load Meter | N. Sanding Belt Tension Lock Lever |
| G. Power Light | O. Sanding Drum |
| H. Sanding Motor ON Button | P. Sanding Belt Tension Lever |



SECTION 1: SAFETY

WARNING

For Your Own Safety, Read Instruction Manual Before Operating this Machine

The purpose of safety symbols is to attract your attention to possible hazardous conditions. This manual uses a series of symbols and signal words intended to convey the level of importance of the safety messages. The progression of symbols is described below. Remember that safety messages by themselves do not eliminate danger and are not a substitute for proper accident prevention measures.



Indicates an imminently hazardous situation which, if not avoided, **WILL** result in death or serious injury.



Indicates a potentially hazardous situation which, if not avoided, **COULD** result in death or serious injury.



Indicates a potentially hazardous situation which, if not avoided, **MAY** result in minor or moderate injury. It may also be used to alert against unsafe practices.

NOTICE

This symbol is used to alert the user to useful information about proper operation of the machine.

WARNING

Safety Instructions for Machinery

- 1. READ THE ENTIRE MANUAL BEFORE STARTING MACHINERY.** Machinery presents serious injury hazards to untrained users.
- 2. ALWAYS USE ANSI APPROVED SAFETY GLASSES WHEN OPERATING MACHINERY.** Everyday eyeglasses only have impact resistant lenses—they are NOT safety glasses.
- 3. ALWAYS WEAR A NIOSH APPROVED RESPIRATOR WHEN OPERATING MACHINERY THAT PRODUCES DUST.** Most types of dust (wood, metal, etc.) can cause severe respiratory illnesses.
- 4. ALWAYS USE HEARING PROTECTION WHEN OPERATING MACHINERY.** Machinery noise can cause permanent hearing loss.
- 5. WEAR PROPER APPAREL. DO NOT** wear loose clothing, gloves, neckties, rings, or jewelry that can catch in moving parts. Wear protective hair covering to contain long hair and wear non-slip footwear.
- 6. NEVER OPERATE MACHINERY WHEN TIRED OR UNDER THE INFLUENCE OF DRUGS OR ALCOHOL.** Be mentally alert at all times when running machinery.



WARNING

Safety Instructions for Machinery

7. **ONLY ALLOW TRAINED AND PROPERLY SUPERVISED PERSONNEL TO OPERATE MACHINERY.** Make sure operation instructions are safe and clearly understood.
8. **KEEP CHILDREN AND VISITORS AWAY.** Keep all children and visitors a safe distance from the work area.
9. **MAKE WORKSHOP CHILDPROOF.** Use padlocks, master switches, and remove start switch keys.
10. **NEVER LEAVE WHEN MACHINE IS RUNNING.** Turn power **OFF** and allow all moving parts to come to a complete stop before leaving machine unattended.
11. **DO NOT USE IN DANGEROUS ENVIRONMENTS.** DO NOT use machinery in damp, wet locations, or where any flammable or noxious fumes may exist.
12. **KEEP WORK AREA CLEAN AND WELL LIGHTED.** Clutter and dark shadows may cause accidents.
13. **USE A GROUNDED EXTENSION CORD RATED FOR THE MACHINE AMPERAGE.** Grounded cords minimize shock hazards. Undersized cords create excessive heat. Always replace damaged extension cords.
14. **ALWAYS DISCONNECT FROM POWER SOURCE BEFORE SERVICING MACHINERY.** Make sure switch is in OFF position before reconnecting.
15. **MAINTAIN MACHINERY WITH CARE.** Keep blades sharp and clean for best and safest performance. Follow instructions for lubricating and changing accessories.
16. **MAKE SURE GUARDS ARE IN PLACE AND WORK CORRECTLY BEFORE USING MACHINERY.**
17. **REMOVE ADJUSTING KEYS AND WRENCHES.** Make a habit of checking for keys and adjusting wrenches before turning machinery **ON**.
18. **CHECK FOR DAMAGED PARTS BEFORE USING MACHINERY.** Check for binding or misaligned parts, broken parts, loose bolts, and any other conditions that may impair machine operation. Repair or replace damaged parts before operation.
19. **USE RECOMMENDED ACCESSORIES.** Refer to the instruction manual for recommended accessories. Improper accessories increase risk of injury.
20. **DO NOT FORCE MACHINERY.** Work at the speed for which the machine or accessory was designed.
21. **SECURE WORKPIECE.** Use clamps or a vise to hold the workpiece when practical. A secured workpiece protects your hands and frees both hands to operate the machine.
22. **DO NOT OVERREACH.** Maintain stability and balance at all times.
23. **MANY MACHINES CAN EJECT WORKPIECES TOWARD OPERATOR.** Know and avoid conditions that cause the workpiece to "kickback."
24. **ALWAYS LOCK MOBILE BASES (IF USED) BEFORE OPERATING MACHINERY.**
25. **CERTAIN DUST MAY BE HAZARDOUS** to the respiratory systems of people and animals, especially fine dust. Be aware of the type of dust you are exposed to and always wear a respirator designed to filter that type of dust.



WARNING

Safety Instructions for Wide Belt Sanders

- 1. READ THIS MANUAL.** This manual contains proper operating and safety procedures for this machine.
- 2. KICKBACK.** Kickback is typically defined as the high-speed expulsion of stock from the machine. Kickback can cause serious personal injury to the operator or bystanders. *Until you have a clear understanding how kickback can occur when using this machine, DO NOT operate this sander!*
- 3. WORKPIECE FEED RATE.** Jamming the workpiece into the sander or against the sanding belt can cause it to kickback into the operator. Always firmly hold the workpiece and ease it into the sander at the same rate as the conveyor.
- 4. AVOIDING ENTANGLEMENT.** Becoming entangled in the moving parts of this machine can cause pinching and crushing injuries. To avoid these hazards, DO NOT wear loose clothing, gloves, or jewelry, and tie back long hair. Keep all guards in place, and cabinet doors closed and secure.
- 5. HAND PLACEMENT.** The sanding belt can remove a large amount of flesh in a few seconds. Always keep hands away from the sanding belt. Avoid pinching injuries by never putting your hand between the workpiece and the machine.
- 6. UNATTENDED MACHINE.** There is risk of unintentional contact with the sanding belt when it is running, resulting in serious injury. Never leave this machine running unattended.
- 7. WORKPIECE QUANTITY.** A fast-moving workpiece ejected from the sander could seriously injure anyone standing near. Never sand two or more workpieces side-by-side. Since workpieces are never exactly the same thickness, one of them may be thrown from the sander at a high rate of speed.
- 8. WORKPIECE INSPECTION.** Nails, staples, knots, or other imperfections in the workpiece can be dislodged and thrown from the sander at a high rate of speed into the operator or bystanders. Never attempt to sand stock that has imperfections or embedded foreign objects.
- 9. BODY PLACEMENT.** In case of kickback, avoid personal injury by always keeping your body to the side of the sanding path.
- 10. WORKPIECE SIZE.** Attempting to sand stock that is thinner, narrower, or shorter than is recommended in this manual can cause kickback or damage to the machine. Always make sure the workpiece is above the minimum size requirements for this sander.
- 11. POWER DISCONNECT.** Accidental start up or contact with live wiring could result in serious personal injury or death. Always disconnect the sander from power when changing the sanding belt, performing maintenance, or servicing the machine.
- 12. EXPERIENCING DIFFICULTY.** If at any time you are experiencing difficulties performing the intended operation, stop using the machine! Contact our Technical Support Department at (570) 546-9663.

CAUTION

No list of safety guidelines can be complete. Every shop environment is different. Always consider safety first, as it applies to your individual working conditions. Use this and other machinery with caution and respect. Failure to do so could result in serious personal injury, damage to equipment, or poor work results.



SECTION 2: CIRCUIT REQUIREMENTS

220V Operation

!WARNING

Serious personal injury could occur if you connect the machine to power before completing the setup process. **DO NOT** connect the machine to the power until instructed later in this manual.

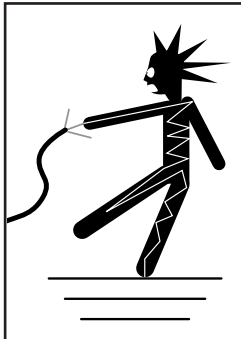

!WARNING

Electrocution or fire could result if machine is not grounded and installed in compliance with electrical codes. Compliance **MUST** be verified by a qualified electrician!

Full Load Amperage Draw

Motor Draw at 220V 15 Amps

Circuit Requirements

You **MUST** connect your machine to a grounded circuit that is rated for the amperage given below. Never replace a circuit breaker on an existing circuit with one of higher amperage without consulting a qualified electrician to ensure compliance with wiring codes. **If you are unsure about the wiring codes in your area or you plan to connect your machine to a shared circuit, consult a qualified electrician.**

Minimum 220V Circuit 20 Amps

Power Connection Device

The type of plug required to connect your machine to power depends on the type of service you currently have or plan to install. We recommend using the plug shown in **Figure 3**.

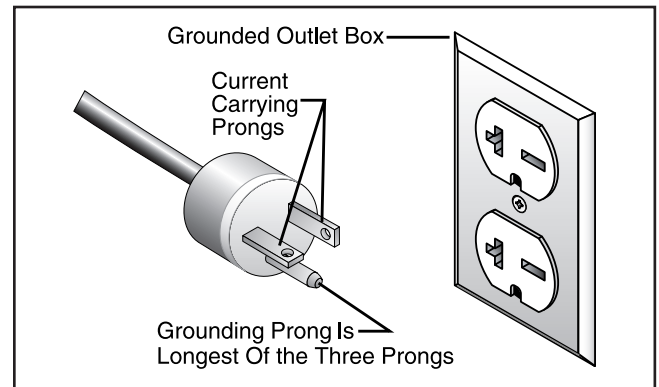

Figure 3. NEMA 6-20 plug and receptacle.

Extension Cords

Using extension cords may reduce the life of the motor. Instead, place the machine near a power source. If you must use an extension cord:

- Use at least a 12 gauge cord that does not exceed 50 feet in length!
- The extension cord must also have a ground wire and plug pin.
- A qualified electrician **MUST** size cords over 50 feet long to prevent motor damage.



SECTION 3: SETUP

Setup Safety

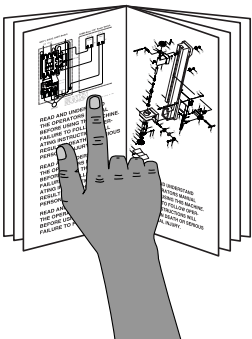

!WARNING
 This machine presents serious injury hazards to untrained users. Read through this entire manual to become familiar with the controls and operations before starting the machine!



!WARNING
 Wear safety glasses during the entire setup process!



!WARNING
 This machine and its components are very heavy. Get lifting help or use power lifting equipment such as a forklift to move heavy items.

Items Needed for Setup

The following items are needed to complete the setup process, but are not included with your machine:

Description	Qty
• Assistant.....	1
• Safety Glasses (for each person)	1
• Wrench 1/2".....	1
• Dust Collection System	1
• 4" Dust Hose (length as needed).....	1
• 4" Hose Clamp	1
• Air Compressor	1
• Air Hose (length as needed)	1
• Forklift (Minimum Rating of 1000 lbs)	1

Unpacking

Your machine was carefully packaged for safe transportation. Remove the packaging materials from around your machine and inspect it. If you discover the machine is damaged, *please immediately call Customer Service at (570) 546-9663 for advice.*

Save the containers and all packing materials for possible inspection by the carrier or its agent. *Otherwise, filing a freight claim can be difficult.*

When you are completely satisfied with the condition of your shipment, inventory the contents.



Inventory

The following is a description of the main components shipped with your machine. Lay the components out to inventory them.

Note: *If you can't find an item on this list, check the mounting location on the machine or examine the packaging materials carefully. Occasionally we pre-install certain components for shipping purposes.*

Box 1: (Figure 4)	Qty
A. Sanding Assembly.....	1
B. Sanding Belt 16" x 48" (not shown)	1
C. Conveyor Front Roller Guard (not shown) .	1

Box 2: (Figure 5)	Qty
D. Cabinet Stand.....	1



Figure 4. Model G0644 box 1 inventory.

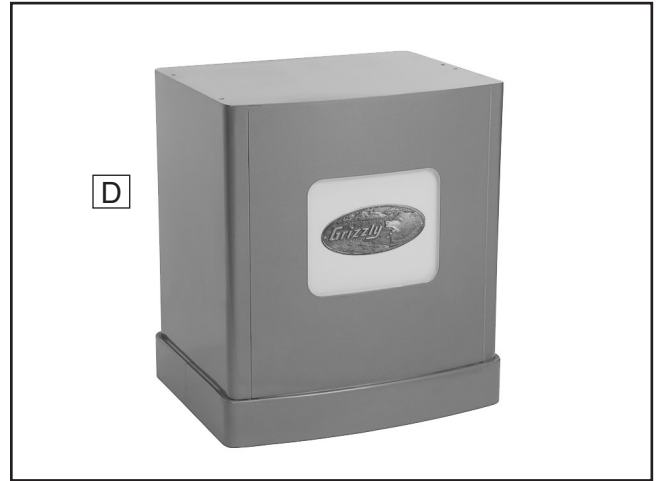

Figure 5. Model G0644 box 2 inventory.

If any nonproprietary parts are missing (e.g. a nut or a washer), we will gladly replace them; or for the sake of expediency, replacements can be obtained at your local hardware store.

	<p>!WARNING SUFFOCATION HAZARD! Immediately discard all plastic bags and packing materials to eliminate choking/suffocation hazards for children and animals.</p>
--	---



Hardware Recognition Chart

USE THIS CHART TO MATCH UP HARDWARE DURING THE ASSEMBLY PROCESS.

MEASURE BOLT DIAMETER BY PLACING INSIDE CIRCLE

- #10
- 1/4"
- 5/16"
- 3/8"
- 7/16"
- 1/2"

- 4mm
- 6mm
- 8mm
- 10mm
- 12mm
- 16mm

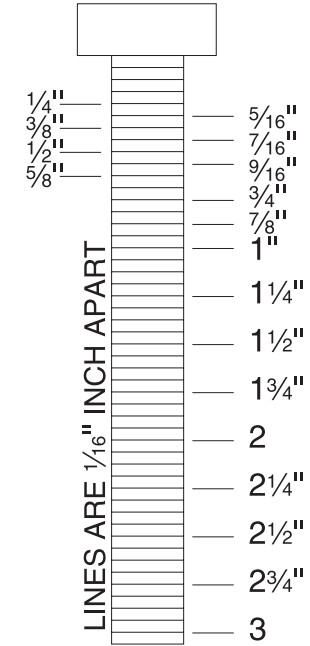
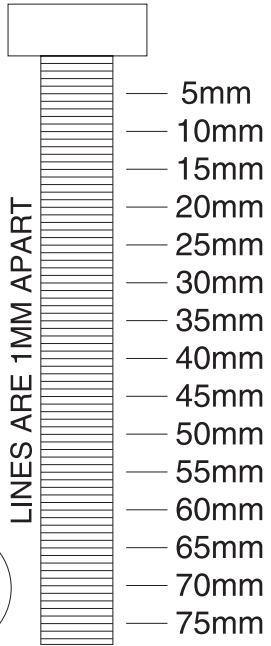
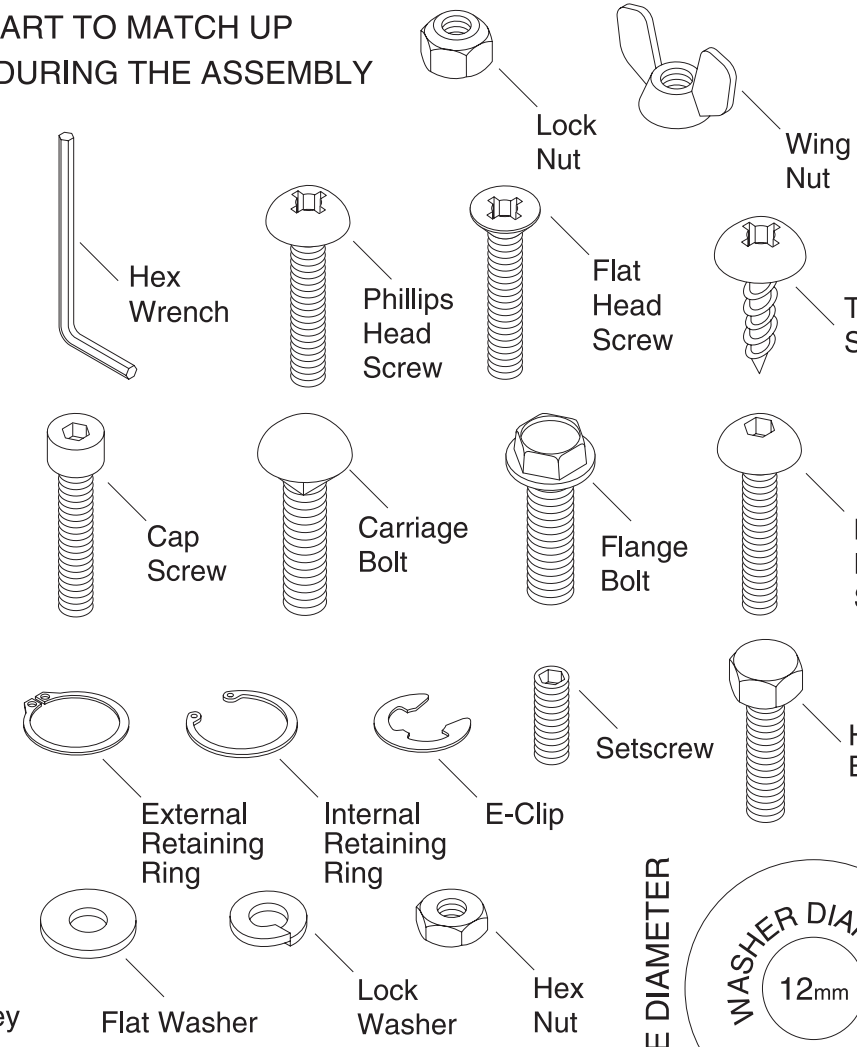

WASHERS ARE MEASURED BY THE INSIDE DIAMETER

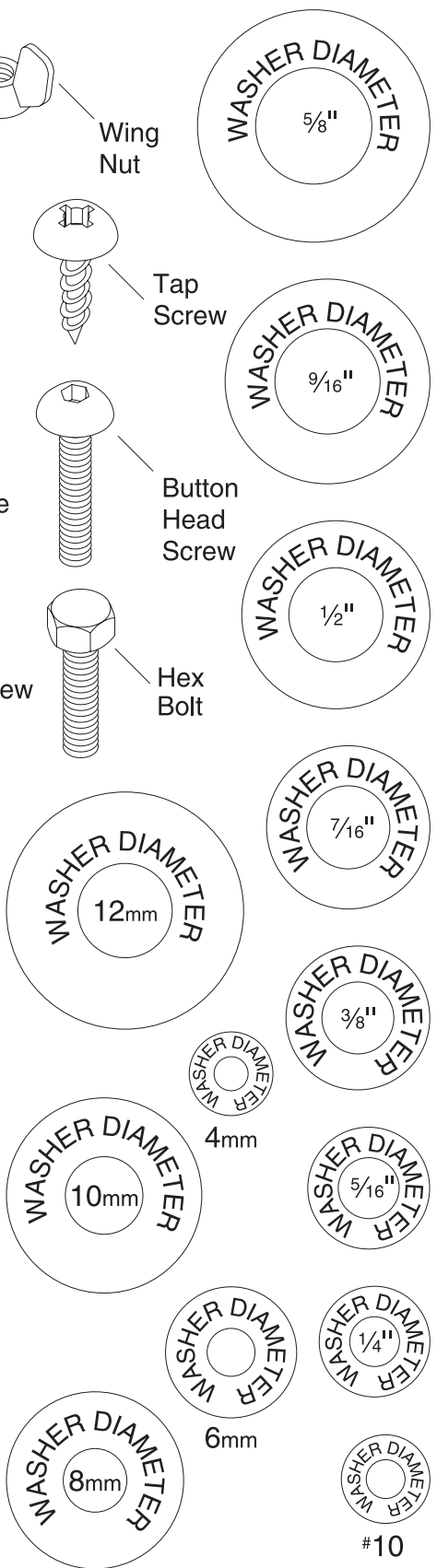

Clean Up

The unpainted surfaces are coated with a waxy oil to prevent corrosion during shipment. Remove this protective coating with a solvent cleaner or citrus-based degreaser such as Grizzly's G7895 Citrus Degreaser. To clean thoroughly, some parts must be removed. **For optimum performance from your machine, clean all moving parts or sliding contact surfaces.** Avoid chlorine-based solvents, such as acetone or brake parts cleaner that may damage painted surfaces. Always follow the manufacturer's instructions when using any type of cleaning product.

	<p>! WARNING Gasoline and petroleum products have low flash points and can explode or cause fire if used to clean machinery. DO NOT use these products to clean the machinery.</p>
--	--

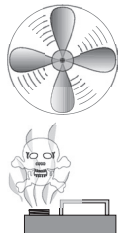
	<p>! CAUTION Many cleaning solvents are toxic if inhaled. Minimize your risk by only using these products in a well ventilated area.</p>
---	---

G7895—Grizzly Citrus Degreaser

This natural, citrus-based degreaser is a great solution for removing export grease, and it's much safer to work around than nasty solvents.

<p>Call 1-800-523-4777 To Order</p>	
--	---

Figure 6. Grizzly citrus degreaser.

Site Considerations

Floor Load

Refer to the **Machine Data Sheet** on **Page 3** for the weight and footprint specifications of your machine. Some residential floors may require additional reinforcement to support both the machine and operator.

Placement Location

Consider existing and anticipated needs, size of material to be processed through each machine, and space for auxiliary stands, work tables or other machinery when establishing a location for your new machine. See **Figure 7** for the minimum working clearances.

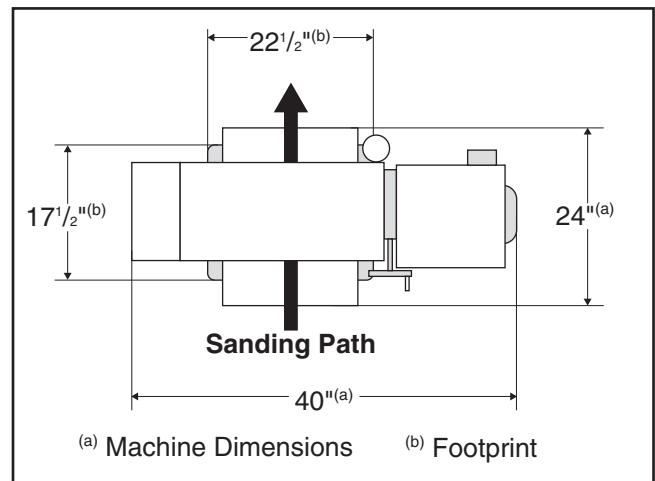
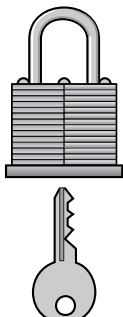

Figure 7. Minimum working clearances.

	<p>! CAUTION Children and visitors may be seriously injured if unsupervised around this machine. Lock entrances to the shop or disable start switch or power connection to prevent unsupervised use.</p>
--	---



Mounting to Shop Floor

The center of gravity of the assembled sander is above the middle of the machine. Although not required, we strongly recommend that you mount your new machine to the floor to prevent tipping. Because this is an optional step and floor materials may vary, floor mounting hardware is not included.

Bolting to Concrete Floors

Anchor studs and lag bolts (Figure 8) are two popular methods for anchoring an object to a concrete floor. We suggest you research the many options and methods for mounting your machine and choose the best that fits your specific application.

NOTICE

Anchor studs are stronger and more permanent alternatives to lag bolts; however, they will stick out of the floor, which may cause a tripping hazard if you decide to move your machine.

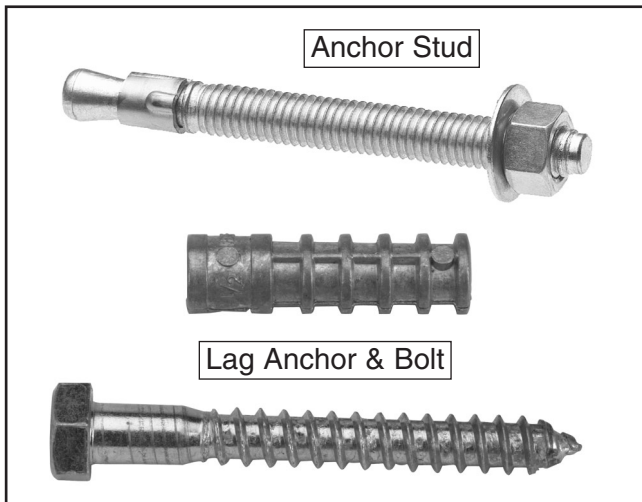
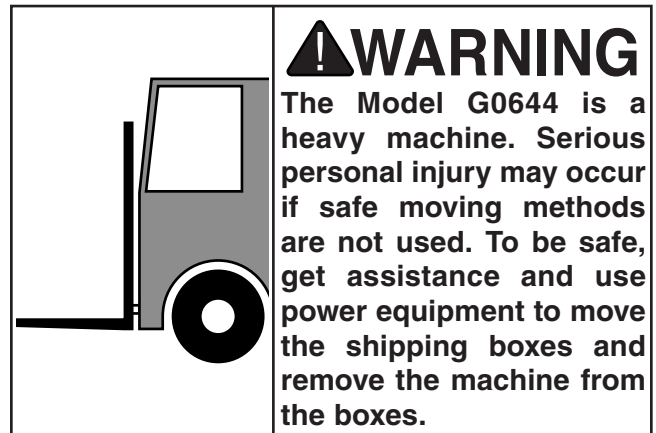

Figure 8. Typical fasteners for mounting to concrete floors.

Moving & Assembling Sander



To move the machine:

1. Mount the cabinet stand to the floor in your prepared location using the four mounting holes found inside the cabinet.
2. Remove the four M8-1.25 x 25 hex bolts and flat washers from the top of the cabinet stand.
3. Place the forklift forks in a stable position under the conveyor, as shown in Figure 9.



Figure 9. Forklift forks positioned under sanding assembly.



4. With an assistant to steady the sanding assembly on the forks, lift and move it into position over the cabinet stand so that the mounting holes line up (see **Figures 10 & 11**).

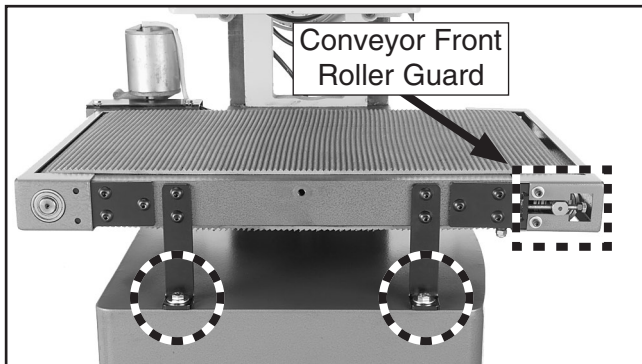

Figure 10. Mounting bolts and conveyor front roller guard (left side).

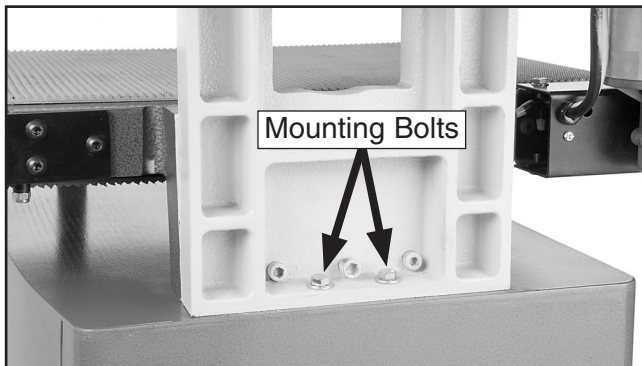

Figure 11. Mounting bolts (right side).

5. Secure the sanding assembly to the cabinet stand with the four hex bolts and flat washers removed in **Step 2**.
6. Remove the four 10-24 x 3/8" cap screws and flat washers from the front of the conveyor, slide the conveyor front roller guard onto the conveyor, and secure it with the cap screws and flat washers (see **Figure 10**).
7. Open the sanding belt access door on the left side of the machine, and remove the red shipping brace securing the sanding drum and the conveyor assembly (see **Figure 12**).

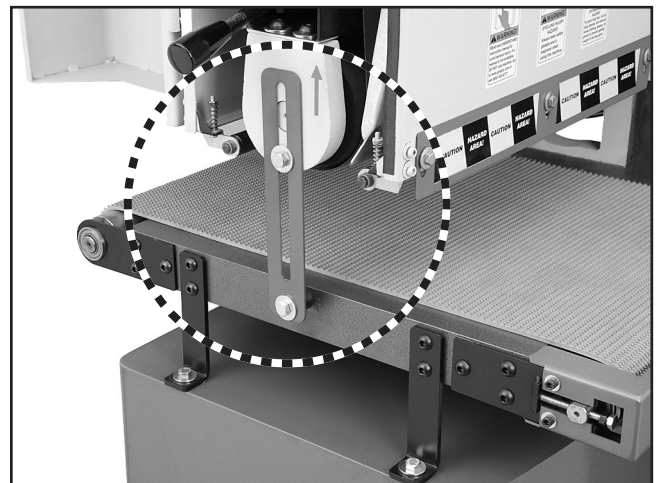

Figure 12. Location of the shipping brace.



8. Connect a source of compressed air to the air regulator inlet valve on the back of the machine.

Note: *The source of compressed air must provide a steady supply of clean, dry air at 57 PSI or more, not to exceed 120 PSI.*

Exceeding 120 PSI may result in unpredictable operation of the sander and damage to the pneumatic system.

9. Lift up on the air regulator adjusting knob (see **Figure 13**), and turn the knob so that the air pressure dial reads 57 PSI, then push the adjusting knob down to lock the setting.

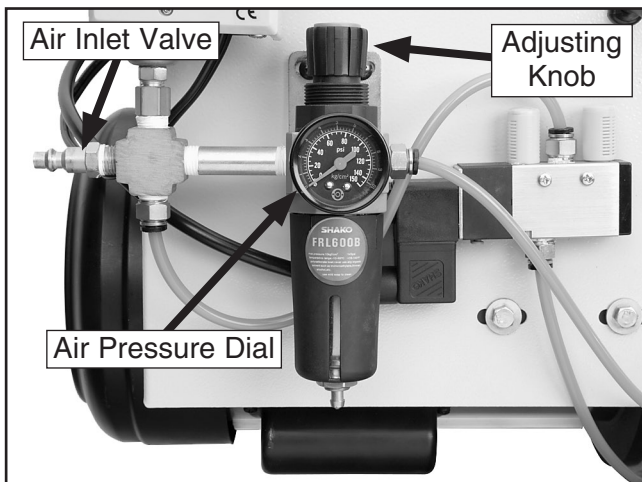

Figure 13. Air regulator unit on back of sander.

Dust Collection

⚠ CAUTION

This sander creates substantial amount of wood dust while operating. Failure to wear a respirator rated for wood dust and use an adequate dust collection system when operating this machine can result in short and long-term respiratory illness.

Minimum CFM at Dust Port: 400 CFM

Do not confuse this CFM recommendation with the rating of the dust collector. To determine the CFM at the dust port, you must consider these variables: (1) CFM rating of the dust collector, (2) hose type and length between the dust collector and the machine, (3) number of branches or wyes, and (4) amount of other open lines throughout the system. Explaining how to calculate these variables is beyond the scope of this manual. Consult an expert or purchase a good dust collection "how-to" book.

To connect a dust collection hose:

1. Fit a 4" dust hose over the dust port on top of the machine, as shown in **Figure 14**, and secure it in place with a hose clamp.
2. Tug the hose to make sure it does not come off. **Note:** *A tight fit is necessary for proper performance.*



Figure 14. Dust hose attached to dust port.



Test Run

Once the assembly is complete, test run your machine to make sure it runs properly and is ready for regular operation.

The test run consists of verifying the following: 1) The motors power up and run correctly, 2) the EMERGENCY STOP button safety feature works correctly, and 3) the conveyor switch disabling mechanism works correctly.

If, during the test run, you cannot easily locate the source of an unusual noise or vibration, stop using the machine immediately, then review **Troubleshooting** on **Page 28**.

If you cannot find a remedy, contact our Tech Support at (570) 546-9663 for assistance.

To test run the machine:

1. Read and follow the safety instructions at the beginning of the manual, and make sure the machine is setup properly.
2. Clear away all tools and objects used during setup.
3. Connect a compressed air source to the air regulator, and set the air pressure dial at 57 PSI.
4. Confirm the sanding belt is installed, tensioned properly (refer to **Sanding Belt Replacement** on **Page 20** for detailed instructions), and the sanding belt access door is closed and secured.
5. Connect the machine to the power source—the Power Light lamp should light.
6. Push the EMERGENCY STOP button in, then twist it clockwise so it pops out. When the button pops out, the switch is reset and ready for operation (see **Figure 15**).



Figure 15. Resetting the EMERGENCY STOP switch.

7. Push the Sanding Motor ON button.
 - When operating correctly, the machine runs smoothly with little or no vibration or rubbing noises.
 - Investigate and correct strange or unusual noises or vibrations before operating the machine further. Always disconnect the machine from power when investigating or correcting potential problems.
8. Press the EMERGENCY STOP button to stop the machine.
9. WITHOUT resetting the switch, press the Sanding Motor ON button. The machine should not start.
 - If the machine does not start, the EMERGENCY STOP button safety feature is working correctly.
 - If the machine does start (with the stop button pushed in), immediately disconnect power to the machine. The EMERGENCY STOP button safety feature is not working correctly. This safety feature must work properly before proceeding with the rest of the test run. Call Tech Support for help.
10. Reset the EMERGENCY STOP button and turn the sanding motor **ON**.

Note: The sanding motor must be **ON** before the conveyor can be started.



11. Turn the conveyor **ON** and verify that it operates correctly.
12. Turn the conveyor belt **OFF**, and remove the switch disabling key, as shown in **Figure 16**.

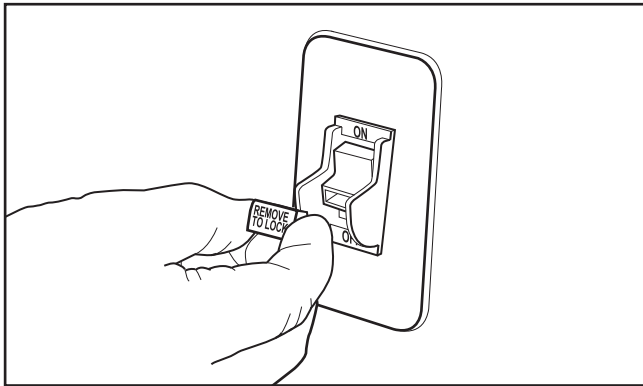

Figure 16. Removing switch key from conveyor toggle switch.

13. Try to start the conveyor by flipping the toggle switch to the ON position.
 - If the conveyor does not start, the switch disabling feature is working as designed.
 - If the conveyor starts, immediately stop the machine. The switch disabling feature is not working correctly. This safety feature must work properly before proceeding with regular operations. Call Tech Support for help.
14. Press the Emergency Stop button to turn the sanding motor **OFF**, re-install the switch disabling key, and reset the Emergency Stop button.
15. Disconnect the compressed air from the sander and attempt to turn the sanding motor **ON**.
 - If the machine does not start, the air pressure safety switch is working correctly.
 - If the machine does start (with the air pressure disconnected), immediately disconnect power to the machine. The air pressure safety switch is not working correctly. This safety feature must work properly before proceeding with the rest of the test run. Call Tech Support for help.

Recommended Adjustments

For your convenience, the adjustments listed below have been performed at the factory and no further setup is required to operate your machine.

However, because of the many variables involved with shipping, some of these adjustments may need to be repeated to ensure optimum results. Keep this in mind as you start to use your new drum sander.

Step-by-step instructions for these adjustments can be found in the **SERVICE** section of this manual.

- Conveyor Belt Tensioning (**Page 30**).
- Conveyor Belt Tracking (**Page 31**).
- Gib Adjustment (**Page 31**).
- Sanding Drum & Conveyor Parallelism (**Page 32**).
- Air Pressure Safety Switch (**Page 33**).
- Depth Of Cut Safety Bar (**Page 33**).
- Pressure Rollers (**Page 34**).



SECTION 4: OPERATIONS

Operation Safety

!WARNING

Damage to your eyes, lungs, and ears could result from using this machine without proper protective gear. Always wear safety glasses, a respirator, and hearing protection when operating this machine.

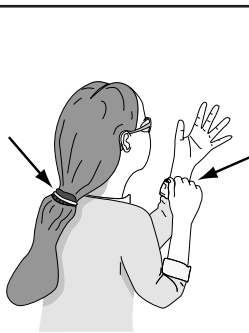
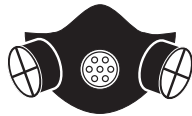

!WARNING

Loose hair and clothing could get caught in machinery and cause serious personal injury. Keep loose clothing and long hair away from moving machinery.

NOTICE

If you have never used this type of machine or equipment before, WE STRONGLY RECOMMEND that you read books, trade magazines, or get formal training before beginning any projects. Regardless of the content in this section, Grizzly Industrial will not be held liable for accidents caused by lack of training.

Sanding Overview

To begin the sanding operation:

1. Connect the sander to the compressed air, and adjust the air regulator for 57 PSI.
2. Make sure the workpiece is clean and free of any defects or foreign materials that might cause kickback or damage the sander.
3. Start the dust collection system.
4. Set the elevation for the correct depth of cut (**Page 22**).
5. Turn the sanding motor **ON**.
6. Turn the conveyor **ON** and correctly adjust the conveyor speed for your operation (**Page 22**).
7. Stand to the side of the sanding path, then firmly hold the workpiece and ease it into the sander at the same rate as the conveyor.
8. While standing to the side of the sanding path, let the conveyor feed the workpiece out of the sander and into your hands.



Choosing Sandpaper

Sanding Belt Size 16"W x 48"L

There are many types of sanding belts to choose from. We recommend aluminum oxide for general workshop environments. **Figure 17** lists groups of abrasives into different classes and shows which grits fall into each class.

Grit	Class	Usage
36	Extra Coarse	Rough sawn boards, thickness sanding, and glue removal.
60	Coarse	Thickness sanding and glue removal.
80–100	Medium	Removing planer marks and initial finish sanding.
120–180	Fine	Finish sanding.

Figure 17. Sandpaper usage chart.

The general rule of thumb is to sand a workpiece with progressively higher grit numbers, with no one grit increase of more than 50. Avoid skipping grits; the larger the grit increase, the harder it will be to remove the scratches from the previous grit.

Ultimately, the type of wood you use and your stage of finish will determine the best grit types to install on your sander.

Sanding Belt Replacement

To change the sanding belt:

1. DISCONNECT THE SANDER FROM POWER!
2. Open the sanding belt access door.
3. Loosen the tension lock lever shown in **Figure 18**.

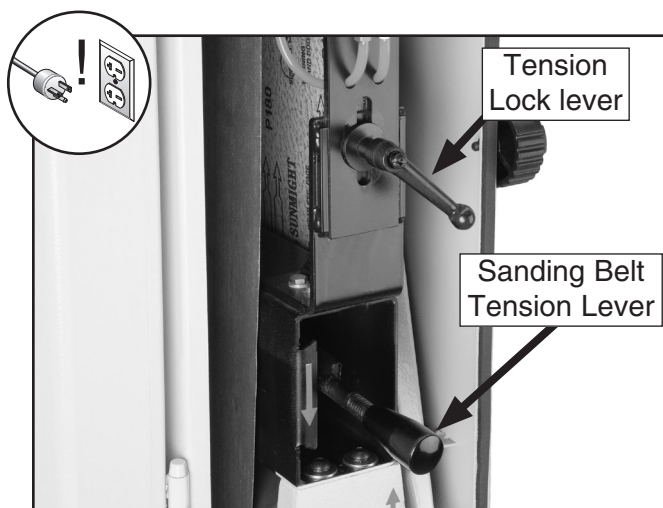

Figure 18. Sanding belt tension controls.



4. Use the sanding belt tension lever to remove the tension on the sanding belt.
 - a. Slightly lift the tension lever, and move it to the right.
 - b. Use moderate force to push the tension lever down, then secure it under the bottom catch, as shown in **Figure 19**.

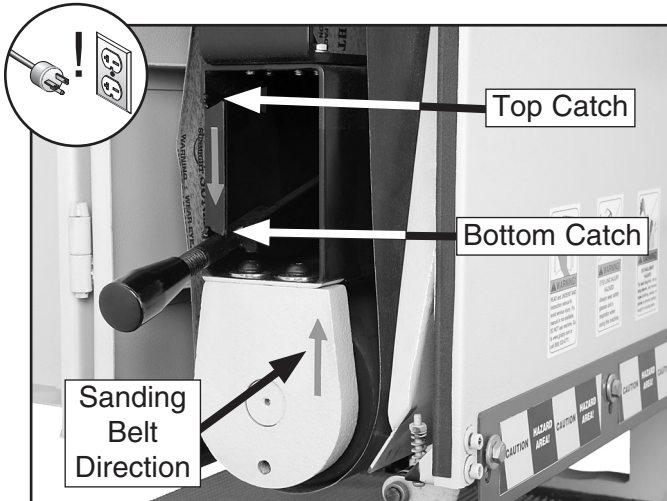

Figure 19. Sanding belt tension lever secured under bottom catch.

5. Pull the sanding belt from the machine.

Note: Some sanding belts are designed to sand in only one direction and have arrows printed on the inside of the belt to show that direction. The front of the sanding drum support has an arrow pointing up showing the direction the sanding belt will travel when in operation (see **Figure 19**). Match these two directions as you install the sanding belt.

⚠ WARNING

The moving sanding belt and roller/drum are an entanglement hazard. To avoid the risk of serious personal injury, always close and secure the sanding belt access door before starting the sanding motor.

6. Slide the new sanding belt onto the upper sanding roller and sanding drum, then position it on the upper sanding roller so that it is just past the left oscillation disc, as shown in **Figure 20**.

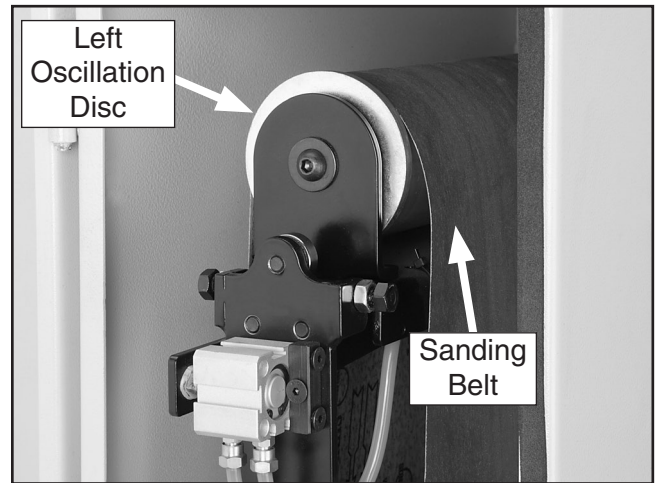

Figure 20. Correct installation position of sanding belt.

7. When you have the sanding belt evenly positioned between the oscillation discs, push down on the sanding belt tension lever, then move it to the right and up onto the top catch.

Note: The Model G0644 automatically applies the correct tension to the sanding belt when the tensioning lever is secured on the top catch.

8. Re-tighten the tension lock lever to secure the sanding belt tension.
9. Close and secure the sanding belt access door before starting the sanding motor.



Conveyor Speed

The conveyor speed dial (see **Figure 21**) adjusts the feed rate from 5–17 FPM. The correct speed to use depends on the type of stock you are using (hardwood vs. softwood) and the stage of finish for the workpiece.

As a general rule, a slower feed rate will sand the surface smoother, but runs the risk of burning the wood; a faster feed rate will remove material faster, but runs the risk of overloading the motor. Use trial-and-error to determine the correct feed rate for your operation.

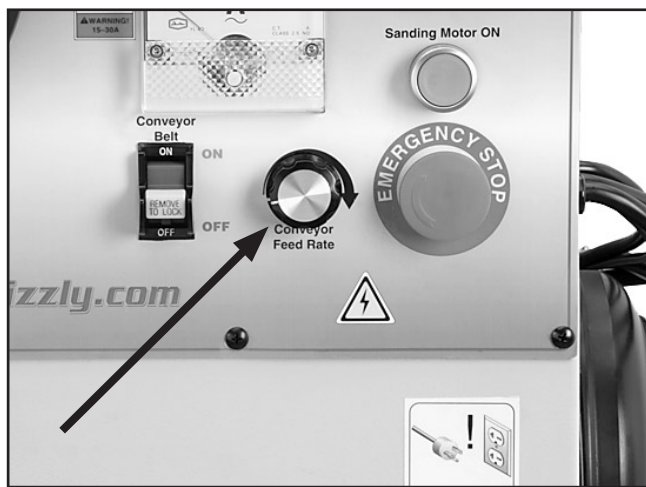

Figure 21. Conveyor speed dial.

Depth of Cut

Recommended maximum depth of cut
..... Approximately $\frac{1}{64}$ " (0.016")

The optimum depth of cut will vary based on the type of wood, feed rate, and sandpaper grit. Attempting to remove too much material can cause jamming, wood burning, rapid paper wear, paper tearing, poor finish, or belt slippage.

Under most conditions, the sanding depth should not exceed $\frac{1}{64}$ " or 0.016" (approximately $\frac{2}{3}$ turn of the elevation handwheel) for each pass. Each full turn of the elevation handwheel raises/lowers the sanding belt approximately 0.025" from the conveyor belt.

When properly adjusted, the depth of cut safety bar (see **Figure 22**) is an excellent tool for setting the *first* depth of cut.

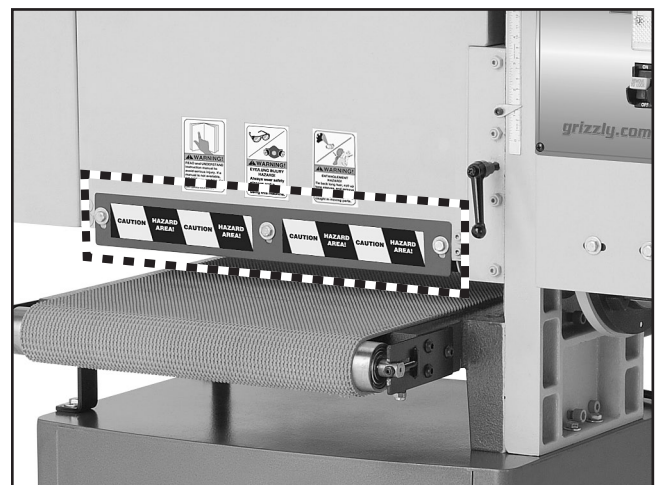

Figure 22. Depth of cut safety bar.

Position the workpiece and sanding cabinet so that the bottom of the safety bar just touches the workpiece. This will set the sanding belt approximately $\frac{1}{64}$ " lower than the workpiece. Then rotate the elevation handwheel one full turn clockwise to raise the sanding belt high enough so that the first pass will take off any high spots. For additional passes, rotate the elevation handwheel $\frac{2}{3}$ of turn clockwise to lower the sanding belt approximately $\frac{1}{64}$ " or 0.016".



The amp load meter on the control panel (see **Figure 23**) shows how much amperage the sanding motor is drawing for the operation. When the depth of cut or conveyor feed rate becomes too great, the sanding motor will draw an excessive power load, which may trip the circuit breaker or damage the machine.

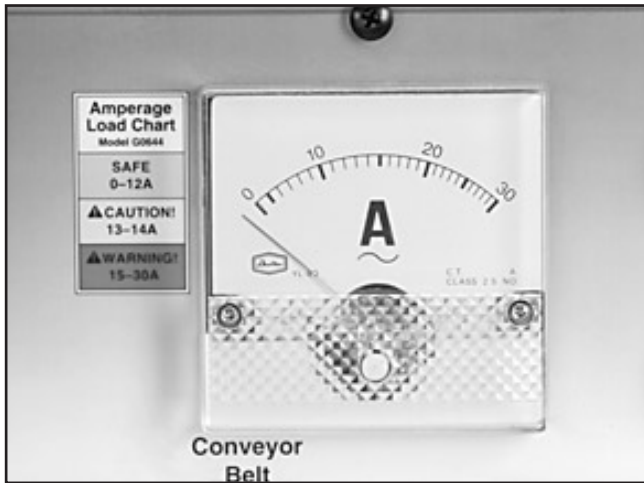

Figure 23. Amp load meter.

NOTICE

DO NOT VOID THE WARRANTY! Keep the amp load within the green *SAFE* range. If you operate the sander above 14 amps or in the red *WARNING* range, capacitor or motor failure may occur and will not be covered under warranty.

Always start with a shallow depth of cut to remove any high spots, then carefully increase the cut depth. Keep the amp load in the **SAFE** range during the entire operation (see **Figure 24**).

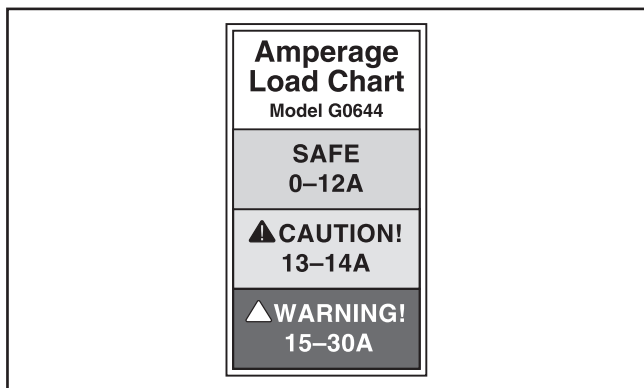

Figure 24. Amp load chart.

Sanding Tips

Follow these instructions to ensure safe sanding operation and quality results:

- Replace the sandpaper with a higher grit to achieve a finer finish (refer to **Choosing Sandpaper** on **Page 20**).
- When making multiple passes on the workpiece, avoid lowering the sanding belt more than $\frac{1}{64}$ " (0.016" or $\frac{2}{3}$ of a turn of the handwheel) for any one pass.
- Feed boards into the sander at different points on the conveyor to maximize sandpaper life and prevent uneven conveyor belt wear.
- **DO NOT** sand boards less than 6" long, 2" wide, or $\frac{1}{4}$ " thick to avoid possible kickback, or damage to the workpiece or sander.
- Extend the life of the sandpaper by regularly using a PRO-STICK® sanding pad (refer to **ACCESSORIES** on **Page 25**).

! WARNING

Starting the sanding motor with a workpiece in contact with the sanding belt could cause it to kickback into the operator resulting in serious personal injury. Never start the sander with a workpiece or any object on the conveyor belt.

Continued on next page →



- When sanding workpieces with irregular widths, take very light sanding passes to prevent gouges. As the width of the workpiece decreases, the load on the sanding motor will reduce and the sanding drum will speed up, causing a gouge.
- DO NOT edge sand boards. This can cause boards to kickback, and may result in serious personal injury. Edge sanding boards also can cause damage to the conveyor belt and sandpaper.
- Feed the workpiece into the sander at an angle to maximize stock removal and sandpaper effectiveness, but feed the workpiece straight to reduce sandpaper grit scratches for the finish passes.
- When sanding workpieces with a bow or crown, place the high point up, which prevents the workpiece from rocking, and take very light passes.

⚠️ WARNING

DO NOT sand more than one board at a time side-by-side. Minor variations in thickness can cause one board to be propelled at a high speed of rate by the sanding belt and could result in serious personal injury.

Sanding Belt Oscillation Rate

To prevent sanding "streaks" in the workpiece, the sanding belt oscillates from side-to-side on the sanding drum during operation. This action is caused by the twisting motion of the upper sanding roller, and is automatically controlled by a pneumatic piston and lever system inside the sanding cabinet.

We recommend that one oscillation cycle (the movement of the sanding belt from one side to the other) should be 4–6 seconds.

Note: You will hear a metallic "thump" when the sanding belt changes oscillation direction. This noise is normal.

The rate of sanding belt oscillation can be changed by adjusting the oscillation stops shown in **Figure 25**.

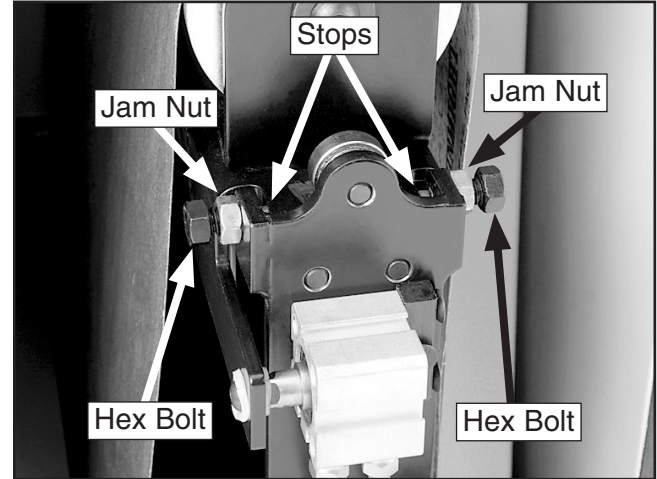

Figure 25. Sanding belt oscillation stops.

To adjust the sanding belt oscillation rate:

1. DISCONNECT THE SANDER FROM POWER!
2. Open the sanding belt access door and identify the oscillation stops shown in **Figure 25**.
3. Use a 12mm wrench to loosen the oscillation stop jam nuts, and adjust the oscillation stop hex bolts equally in or out to change the oscillation rate.

Note: The farther in towards the center you adjust the hex bolt, the slower the sanding belt will oscillate for that direction of movement. Experiment to find the right oscillation rate for your operation.

4. Re-tighten the jam nuts, and close the access door.
5. Connect the machine to power, start the sanding motor, and check the oscillation rate. Repeat **Steps 1–4** if necessary.

NOTICE

The sanding belt oscillation system requires compressed air connected to the machine and adjusted to 57 PSI. Without this compressed air, the sander will not operate.



SECTION 5: ACCESSORIES

G8027—1 HP Dust Collector

A great little workhorse at an incredible price! This is a great machine for sanders, router tables, shapers, and other work. It's also very portable, so you can take it to the job site. Air suction capacity: 500 CFM.



Figure 26. G8027 dust collector.

H2845—PRO-STICK® Sanding Pad

Extend the life of your sandpaper! Just feed this crepe-rubber cleaning pad through your drum sander to remove dust build-up from the sandpaper without damage. 15" X 20" X 1 1/8"



Figure 27. PRO-STICK® sanding pad.

G8982—Shop Fox Roller Table

Use this versatile roller table wherever you need extra workpiece support. Features all steel welded construction and measures 19" x 65" long. Comes with 9 ball bearing rollers and has four independently adjustable legs for any leveling requirement. Adjustable in height from 26 3/8" to 44 1/8".



Figure 28. G8982 Shop Fox roller table.

Aluminum Oxide Sanding Belts 16"W x 48"L

Siawood TopTec sanding belts provide the advantages of: high stock removal rates in coarse grit sizes when sanding soft and hard wood; high surface quality using fine grit sizes; low dust adhesion on the abrasive belt, work piece, and machine, thanks to the anti-static treatment; application-specific optimization of the belt joints; and the long-term use provided by sturdy backing. The end result? Perfect surface quality!

H8739—60 Grit

H8740—80 Grit

H8741—100 Grit

H8742—120 Grit

H8743—150 Grit

H8744—220 Grit

Call 1-800-523-4777 To Order



SECTION 6: MAINTENANCE

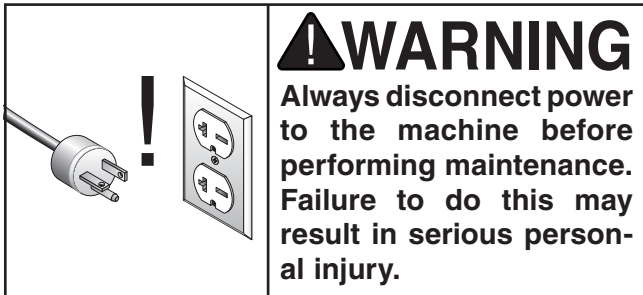

Schedule

For optimum performance from your machine, follow this maintenance schedule and refer to any specific instructions given in this section.

Daily:

- Check/tighten loose mounting bolts.
- Check/replace damaged or worn sanding belt.
- Check and repair/replace worn or damaged wires.
- Check/resolve any other unsafe condition.

Bi-Monthly:

- Check/lubricate elevation dovetail way.
- Check/lubricate Elevation gear.
- Check/empty air regulator filter reservoir.

Cleaning

Vacuum excess sawdust, and wipe off the remaining dust with a dry cloth.

Use warm soapy water to clean the conveyor belt. DO NOT use corrosive or solvent-base cleaners.

Extend the life of the sandpaper by regularly using a PRO-STICK® sanding pad (refer to **ACCESSORIES** on **Page 25**).

Lubrication

The bearings are factory lubricated and sealed and require no further lubrication. Simply leave them alone unless they need replacement.

The devices that do require lubrication are the elevation dovetail way and gears. Keep these devices adequately lubricated so that elevation adjustments move smoothly.

To lubricate the elevation gibs:

1. DISCONNECT THE SANDER FROM POWER!
2. Raise and lower the sanding cabinet to access the entire length of the front and rear dovetail way (see **Figure 29**).

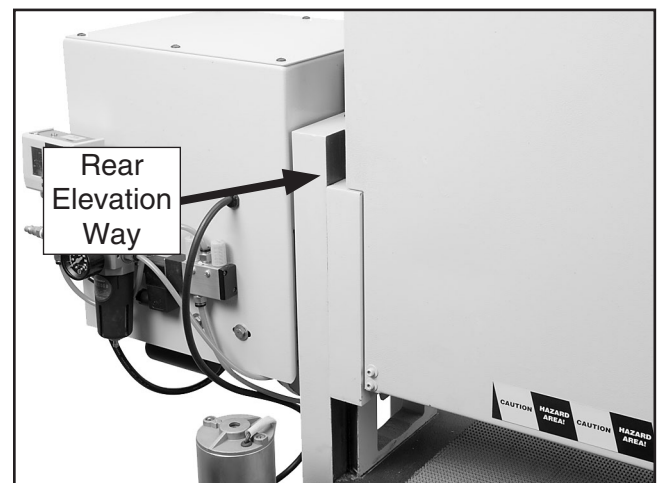

Figure 29. Elevation dovetail way on rear of the sander.

3. Clean off any debris from the dovetail way and apply a thin coat of light machine oil.
4. Move the sanding cabinet through its entire range of motion to evenly distribute the oil.



To lubricate the elevation gears:

1. DISCONNECT THE SANDER FROM POWER!
2. Use a 4mm hex wrench to loosen the set screw in the elevation handwheel hub, then remove the handwheel to access the elevation gears, as shown in **Figure 30**.

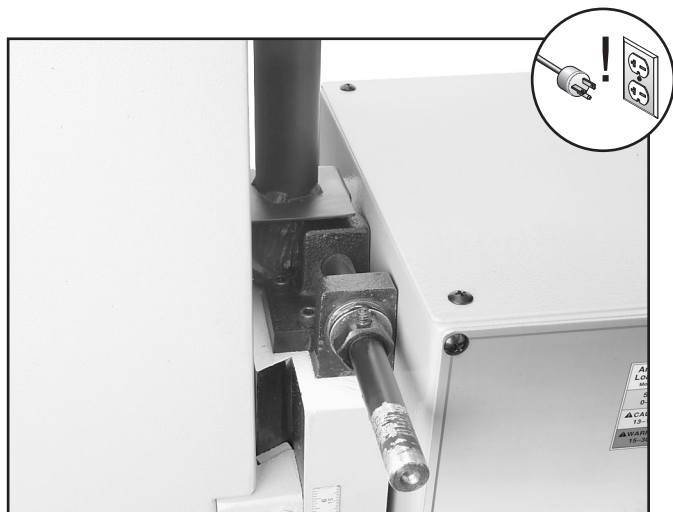

Figure 30. Elevation gears (elevation handwheel removed).

3. Apply a small amount of multi-purpose grease on the gears.
4. Reinstall the handwheel, then move the sanding cabinet through its entire range of movement to evenly distribute the lubricant.

Air Regulator/Filter

The air regulator filters the incoming compressed air and deposits the collected water in the filter reservoir (see **Figure 31**).

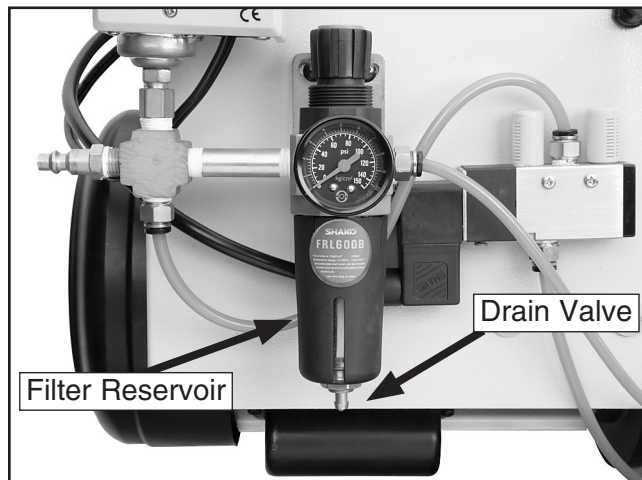

Figure 31. Air regulator filter reservoir and drain valve.

To empty the filter reservoir, make sure there is incoming air pressure and press the drain valve up. This will release a flow of air and the collected water.



SECTION 7: SERVICE

Review the troubleshooting and procedures in this section to fix or adjust your machine if a problem develops. If you need replacement parts or you are unsure of your repair skills, then feel free to call our Technical Support at (570) 546-9663.

Troubleshooting

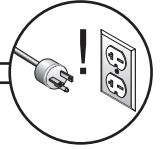

Motor & Electrical

Symptom	Possible Cause	Possible Solution
Motor does not start or a breaker trips.	<ol style="list-style-type: none"> 1. Compressed air to the machine is not at 57 PSI. 2. Sanding motor is not on (conveyor motor). 3. Emergency stop push-button is engaged/faulty. 4. Air pressure safety switch is at fault. 5. Switch disabling key is removed (conveyor motor). 6. Plug/receptacle is at fault or wired incorrectly. 7. Start capacitor is at fault. 8. Conveyor speed dial is at fault. 9. Motor connection wired incorrectly. 10. Wall fuse/circuit breaker is blown/tripped. 11. Thermal overload relay has tripped. 12. Contactor not getting energized/has burnt contacts. 13. Power supply switched OFF or is at fault. 14. Wiring is open/has high resistance. 15. Motor ON button (sanding motor) or ON/OFF switch (conveyor motor) is at fault. 16. Centrifugal switch is at fault. 17. Motor is at fault. 	<ol style="list-style-type: none"> 1. Connect clean, dry compressed air to the machine at 57 PSI. 2. Turn sanding motor on before conveyor motor. 3. Rotate clockwise slightly until it pops out/replace it. 4. Test/replace air pressure safety switch; adjust (Page 33). 5. Install switch disabling key. 6. Test for good contacts; correct the wiring. 7. Test/replace if faulty. 8. Test/replace if faulty. 9. Correct motor wiring connections. 10. Ensure circuit size is suitable for this machine; replace weak breaker. 11. Turn cut-out dial to increase working amps and push the reset pin. Replace if tripped multiple times (weak relay). 12. Test for power on all legs and contactor operation. Replace unit if faulty. 13. Ensure power supply is switched on; ensure power supply has the correct voltage. 14. Check for broken wires or disconnected/corroded connections, and repair/replace as necessary. 15. Replace faulty ON button or ON/OFF switch. 16. Adjust/replace the centrifugal switch if available. 17. Test/repair/replace.
Machine has vibration or noisy operation (a metallic "thump" sound during operation is normal).	<ol style="list-style-type: none"> 1. Motor or component is loose. 2. Motor mount loose/broken. 3. Motor fan is rubbing on fan cover. 4. Motor bearings are at fault. 5. Centrifugal switch at fault. 	<ol style="list-style-type: none"> 1. Inspect/replace stripped or damaged bolts/nuts, and re-tighten with thread locking fluid. 2. Tighten/replace. 3. Replace dented fan cover; replace loose/damaged fan. 4. Test by rotating shaft; rotational grinding/loose shaft requires bearing replacement. 5. Replace.



Motor & Electrical (continued)

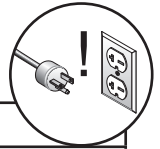

Symptom	Possible Cause	Possible Solution
Motor stalls or is overloaded.	<ol style="list-style-type: none"> 1. Sanding depth too aggressive. 2. Workpiece material is not suitable for this machine. 3. Conveyor speed too fast for task. 4. Dust collection ducting is poor. 5. Air pressure brake solenoid is at fault. 6. Run capacitor is at fault. 7. Conveyor speed dial is at fault. 8. Motor connection is wired incorrectly. 9. Plug/receptacle is at fault. 10. Motor bearings are at fault. 11. Machine is undersized for the task. 12. Motor has overheated. 13. Contactor not getting energized or has poor contacts. 14. Motor is at fault. 15. Centrifugal switch is at fault. 	<ol style="list-style-type: none"> 1. Reduce sanding depth or install coarser sandpaper. 2. Only sand wood products; make sure moisture content is below 20% and there are no foreign materials in the workpiece. 3. Decrease conveyor speed (feed rate). 4. Seal all leaks, size ducts correctly, eliminate bends, and refer to Dust Collection Basics Handbook (ISBN 0-9635821-2-7) for further recommendations. 5. Test/replace. 6. Test/replace. 7. Test and replace if faulty. 8. Correct motor wiring connections. 9. Test for good contacts; correct the wiring. 10. Test by rotating shaft; rotational grinding/loose shaft requires bearing replacement. 11. Use new sandpaper with appropriate grit; reduce the feed rate/depth of sanding. 12. Clean off motor, let cool, and reduce workload. 13. Test for power on all legs and contactor operation. Replace if faulty. 14. Test/repair/replace. 15. Adjust/replace centrifugal switch if available.

Sanding Operation

SYMPTOM	POSSIBLE CAUSE	CORRECTIVE ACTION
Grit rubs off the belt easily.	<ol style="list-style-type: none"> 1. Sanding belt has been stored in an incorrect environment. 2. Sanding belt has been folded or smashed. 	<ol style="list-style-type: none"> 1. Store sanding belt away from extremely dry or hot temperatures. 2. Store sanding belt flat, not folded or bent.
Sanding surfaces clog quickly or burn.	<ol style="list-style-type: none"> 1. Sanding depth too aggressive. 2. Sanding softwood. 	<ol style="list-style-type: none"> 1. Reduce sanding depth or install coarser sandpaper. 2. Use different stock. Or, accept the characteristics of the stock and plan on cleaning/replacing belts frequently.
Burn marks on workpiece.	<ol style="list-style-type: none"> 1. Using too fine of sanding grit. 2. Sanding depth too aggressive. 3. Work held still for too long. 	<ol style="list-style-type: none"> 1. Use a coarser grit sanding belt. 2. Reduce sanding depth or install coarser sandpaper. 3. Do not keep workpiece in one place for too long.
Glazed sanding surfaces.	<ol style="list-style-type: none"> 1. Sanding wet stock. 2. Sanding stock with high residue. 	<ol style="list-style-type: none"> 1. Dry stock properly before sanding. 2. Use different stock. Or, accept the characteristics of the stock and plan on cleaning/replacing sanding belts frequently.
Workpiece slips on conveyor belt.	<ol style="list-style-type: none"> 1. Dirty conveyor belt. 2. Conveyor belt is worn. 	<ol style="list-style-type: none"> 1. Clean conveyor belt. 2. Replace conveyor belt.
Uneven thickness from left to right of board.	<ol style="list-style-type: none"> 1. Sanding drum not parallel to conveyor. 2. Conveyor belt is worn. 	<ol style="list-style-type: none"> 1. Adjust the conveyor to sanding drum parallelism (Page 32). 2. Replace conveyor belt.
Machine is loud, overheats or bogs down in the cut.	<ol style="list-style-type: none"> 1. Excessive depth of cut. 2. Dull sanding belt. 	<ol style="list-style-type: none"> 1. Decrease depth of cut. 2. Replace sanding belt.



Conveyor Belt Tensioning

The conveyor belt may stretch with extended use, causing it to slip on the conveyor rollers. If this happens, the conveyor belt will need to be retensioned.

When you tension the conveyor belt, make sure you turn the left and right adjustment bolts in even increments. Tensioning one side more than the other will cause tracking problems, which will require you to take additional steps to get the sander operating correctly.

To tension the conveyor belt:

1. Take the reference measurement shown in **Figure 32** on both sides of the conveyor.

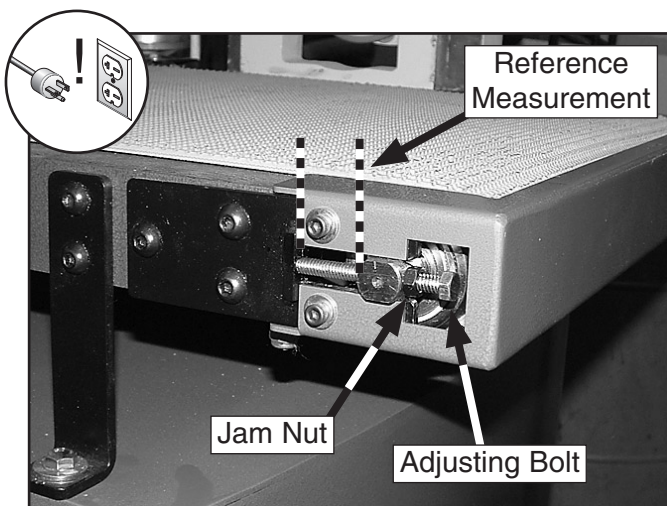

Figure 32. Conveyor belt adjusting bolts (one side shown).

2. Use a 10mm wrench to loosen the jam nuts on both sides of the conveyor.

3. Turn both of the adjustment bolts clockwise one full turn at a time until the conveyor belt no longer slips during operation.

Note: Make sure the distance of the reference measurement taken in **Step 1** is the same on both sides.

—If the conveyor belt starts tracking to one side, immediately turn the conveyor **OFF** and perform the tracking procedure below.

Note: Do not overtighten the conveyor belt. Your goal is reach an approximate $\frac{1}{2}$ " hanging gap on the underside of the conveyor belt (see **Figure 33**) and that the belt no longer slips on the rollers.

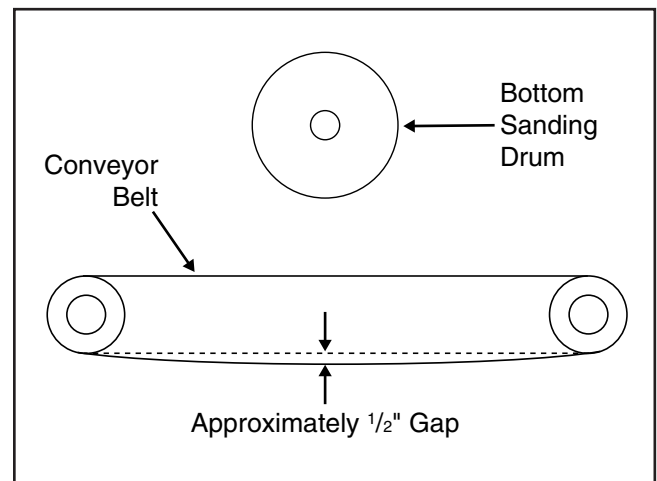

Figure 33. Correct conveyor belt hanging gap.

4. Re-tighten the jam nuts to lock the adjustment bolts in place.



Conveyor Belt Tracking

If the conveyor belt tracks to either side, the belt could become damaged and have to be replaced.

Adjusting the conveyor belt tracking is a balancing process that takes patience and some trial-and-error. You must tighten the loose side adjusting bolt (the side the belt is tracking towards) to make the belt move to the middle of the rollers, then loosen that same adjusting bolt to make the conveyor stay in position.

To adjust the conveyor belt tracking:

1. Make sure the conveyor is properly tensioned (**Page 30**).

1. Turn the conveyor **ON** and watch it track.
2. Determine which side the conveyor belt is tracking towards, and tighten the adjustment bolt (see **Figure 32**) on that side until the belt tracks in the opposite direction.

Note: Tracking changes may take a couple of minutes before they are noticeable.

3. When the conveyor belt is near the middle of the rollers, loosen the same adjusting bolt until the conveyor stops moving to the side and tracks straight.

—If the belt tracks too far to the other side, tighten the adjusting bolt as necessary to bring it back, then repeats **Steps 2 & 3** until the tracking is correct.

Gib Adjustment

The gib controls the accuracy of sanding cabinet movement along the dovetail way. A tight gib makes the movement more accurate, but harder to move, and will lead to premature wear of the ways. A loose gib makes the movements and measurements sloppy, but easier to move. The goal of gib adjustment is to remove unnecessary sloppiness without causing the dovetail way to bind.

To adjust the gib:

1. DISCONNECT THE SANDER FROM POWER!
2. Clean and lubricate the dovetail way and gears (**Page 26**).
3. Loosen the four gib jam nuts along the column shown in **Figure 34**.



Figure 34. Gib jam nuts and set screws.

4. Adjust the gib set screws evenly until there is a slight drag on the dovetail way as you move the sanding cabinet up and down.
5. Re-tighten the gib jam nuts.



Sanding Drum & Conveyor Parallelism

The sanding drum and conveyor must be parallel to one another to obtain accurate sanding results. This setting is made at the factory and should not have to be made again. However, if it is necessary to adjust the sanding drum and conveyor parallel to each other, follow the procedure below.

This process involves multiple accurate measurements, patience, and trial-and-error. The goal is to bring the sanding drum and conveyor parallel to one another within 0.005" from side-to-side.

Using a dial indicator is probably the most accurate method of taking measurements for this procedure. However, you can use gauge blocks and feeler gauges to attain acceptable results.

To make gauge blocks, square up a 7' long 2x4 (refer to your jointer manual for detailed instructions), then cut it in half.

To check the sanding drum and conveyor parallelism:

1. DISCONNECT THE SANDER FROM POWER!
2. Remove the sanding belt from the sander.
3. Record the precise measurements between the lowest point of the sanding drum and the conveyor from side-to-side.

—If the measurements differ more than 0.005" from side-to-side, continue to the next set of steps to adjust the sanding drum and conveyor parallelism.

To adjust the sanding drum and conveyor parallelism:

Note: Use the measurements you recorded when checking the parallelism in the previous procedure.

1. Loosen the four mounting cap screws on the right side of the column base shown in **Figure 35**.

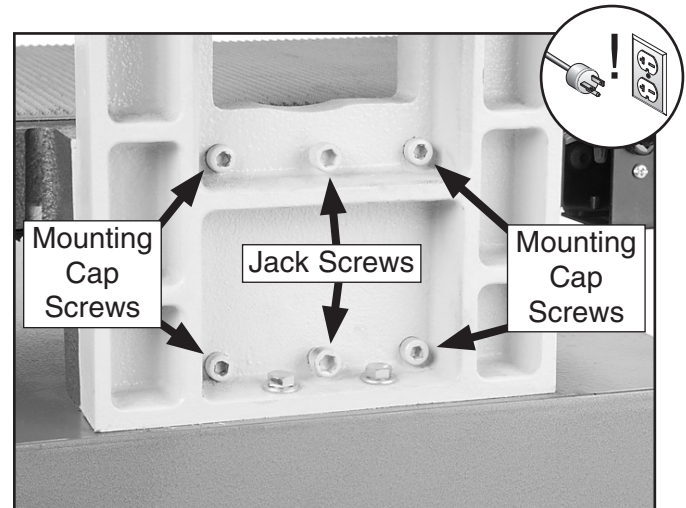

Figure 35. Column mounting cap screws and jack screws.

2. Tighten or loosen the upper or lower jack screw to bring the sanding drum and conveyor parallel to one another to within 0.005" from side-to-side.
 - To raise the left side of the sanding drum up, tighten the upper jack screw.
 - To lower the left side of the sanding drum, tighten the lower jack screw.
3. Evenly re-tighten the four mounting cap screws.
4. Plane a 15" wide piece of stock, then send it through the sander until it is flat.
5. Use a caliper to measure this workpiece from side-to-side. If these measurements differ more than 0.005", repeat **Steps 1–4** until you are satisfied.



Air Pressure Safety Switch

The sanding motor safety brake and the sanding belt oscillation system require at least 57 PSI of air pressure connected to the machine to operate correctly. The air pressure safety switch (see **Figure 36**) measures the amount of air pressure flowing into the machine. If there is not adequate air pressure, the air pressure safety switch will not allow power to flow to the sander.

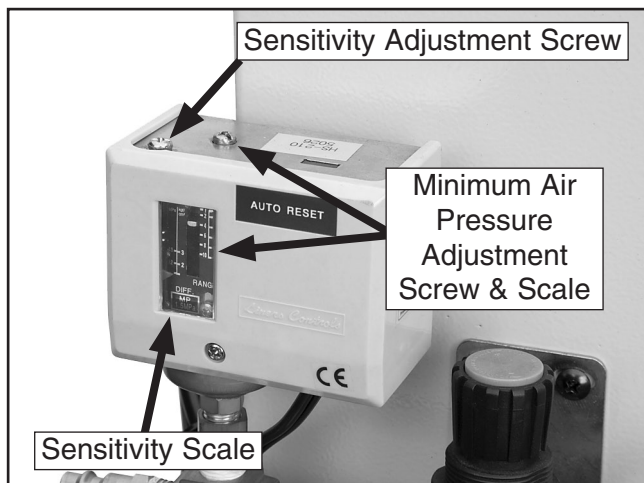

Figure 36. Air pressure safety switch.

The air pressure safety switch was calibrated and set at the factory and should not require any further adjustment. However, we recommend that you verify the settings.

The red pointer on the sensitivity scale should be set at "0" on the scale, which is adjusted with the sensitivity adjustment screw shown in **Figure 36**. The left minimum air pressure scale should read 4 kg/cm², which is adjusted with the related adjustment screw.

Adjusting Depth Of Cut Safety Bar

When properly adjusted, prevents the operator from exceeding the maximum depth of cut.

The position of this safety bar (see **Figure 37**) was factory set at approximately $\frac{3}{64}$ " (0.047") above the lowest point of the sanding drum. We recommend that this safety bar remain at this setting.

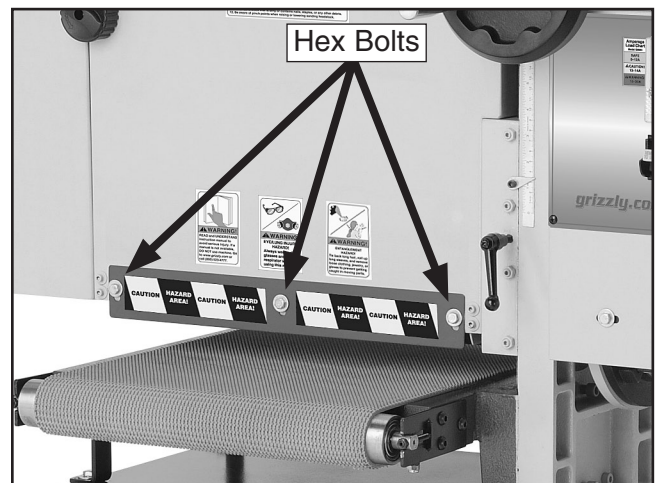

Figure 37. Depth of cut safety bar.

To adjust the depth of cut safety bar to the factory setting:

1. Make sure the sanding drum and conveyor are parallel (**Page 32**).
2. Sand a 15" wide piece of stock until it is flat.
3. **DISCONNECT THE SANDER FROM POWER!**
4. Open the sanding belt access door and remove the sanding belt from the sander.



5. Place the sanded workpiece under the sanding drum and lower the sanding cabinet until the sanding drum is just touching the workpiece.
6. Remove the workpiece from under the sanding drum and position it directly under the depth of cut safety bar.
7. Loosen the three hex bolts securing the safety bar.
8. Use feeler gauges to raise the safety bar approximately $\frac{3}{64}$ " (0.047") above the workpiece from side-to-side.
9. Re-tighten the hex bolts.
10. Re-install the sanding belt and secure the access door.

Adjusting Pressure Rollers

The height of the pressure rollers (see **Figure 38**) is set below the sanding drum to keep the workpiece firmly against the conveyor belt as it passes through the sander, preventing workpiece kickback.

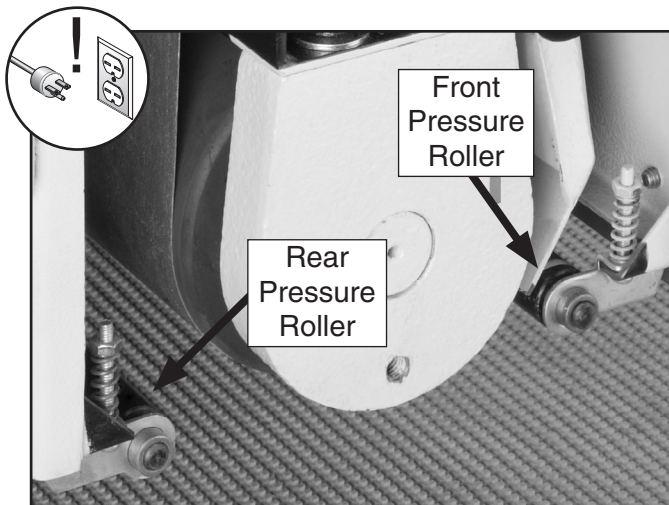

Figure 38. Pressure rollers.

The pressure roller height was factory set at approximately $\frac{1}{16}$ " (0.063") below the lowest point of the sanding drum.

To adjust the height of the pressure rollers:

1. Make sure the sanding drum and conveyor are parallel (**Page 32**).
2. Sand a 15" wide piece of stock until it is flat.
3. **DISCONNECT THE SANDER FROM POWER!**
4. Open the sanding belt access door and remove the sanding belt from the sander.
5. Loosen the eight cap screws securing the front and rear pressure rollers to the sanding cabinet (see **Figure 39**).

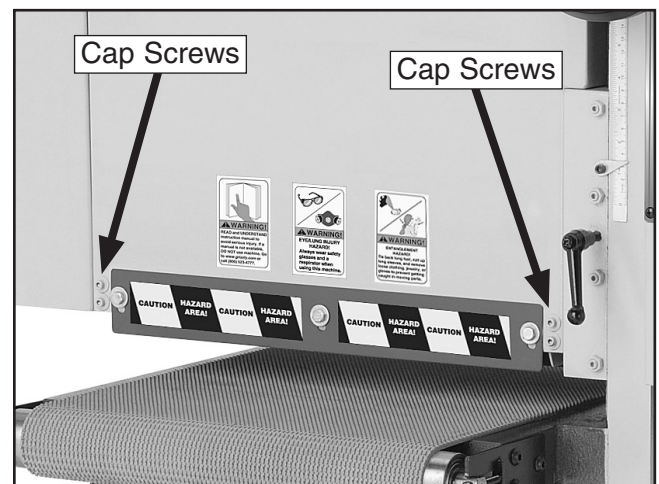

Figure 39. Pressure roller cap screws (front pressure roller cap screws shown)

6. Place the workpiece under the sanding drum.
7. Use feeler gauges to position the sanding drum approximately $\frac{1}{16}$ " (0.063") above the sanded workpiece from **Step 2**.
8. Adjust the pressure rollers so that they are lightly resting on the workpiece from side-to-side, then re-tighten the cap screws to secure the pressure rollers in place.
9. Re-install the sanding belt and secure the access door.



Replacing Conveyor Belt

Contact Grizzly Customer Service at (800) 523-4777 to obtain a replacement conveyor belt (Part Number P0644024).

To replace the conveyor belt:

1. DISCONNECT THE SANDER FROM POWER!
2. Use a 4mm hex wrench to remove the M4-.7 x 10 cap screws and flat washers securing the front and rear conveyor roller guards (see **Figure 40**), then remove the guards.

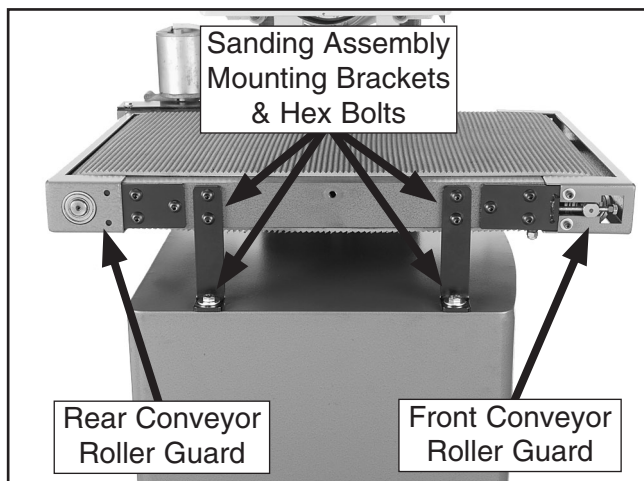

Figure 40. Conveyor roller guards and sanding assembly mounting brackets.

3. Use a 10mm wrench to loosen the conveyor adjusting jam nuts (left and right), then release the tension on the conveyor belt by loosening the tension adjusting hex bolts (see **Figure 41**).

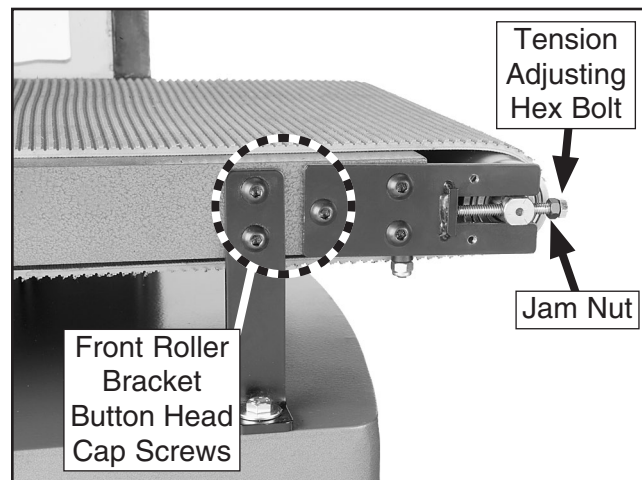

Figure 41. Conveyor belt tensioning fasteners and front roller bracket.

4. Use a 5mm hex wrench to remove the three M8-1.25 x 18 button head cap screws securing the left front conveyor roller bracket (see **Figure 41**), then, while supporting the front conveyor roller assembly, remove the bracket.
5. Carefully pull the front conveyor roller assembly from the conveyor belt and the right front roller bracket.

NOTICE

Take care not to scratch or dent the front conveyor roller as you remove it from the sander. Damage to the conveyor roller could result in premature wear of the conveyor belt.



- Use a 5mm hex wrench to remove the three M8-1.25 x 18 button head cap screws securing left rear conveyor roller bracket, leaving the rear conveyor roller assembly and bracket in place (see **Figure 42**).

Note: After loosening the left conveyor roller bracket, the rear conveyor roller assembly is supported by its attachment to the conveyor motor assembly. However, to avoid damaging this roller assembly, **DO NOT** put unnecessary strain on it.

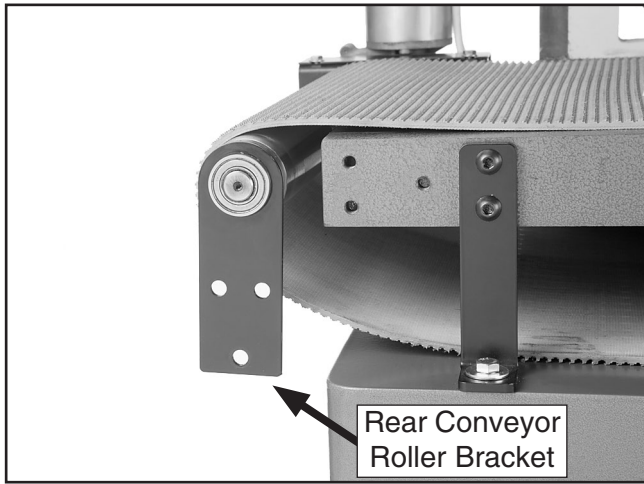

Figure 42. Rear conveyor roller bracket unattached.

- Loosen the four upper button head cap screws securing the sanding assembly mounting brackets to the conveyor (see **Figure 40**).

Note: Loosening these fasteners will relieve the strain on the brackets for the next step.

- Use a 12mm hex wrench to remove the two $\frac{5}{16}$ "-18 x 1" hex bolts, flat washers, and hex nuts securing the left sanding assembly mounting brackets (see **Figure 40**).

Note: Reach into the cabinet stand to reach the hex nuts.

- With assistance, carefully lift the sanding assembly up and remove the conveyor belt, as shown in **Figure 43**.

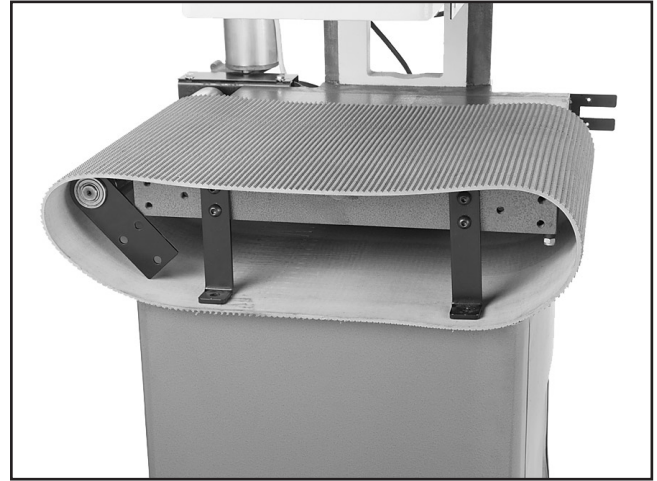

Figure 43. Conveyor belt partially removed from the sander.

- Slide the new conveyor belt onto the conveyor and re-install the parts in reverse order.

Note: Make sure the conveyor roller brackets are mounted with the small flange facing out, as shown in **Figure 44**.

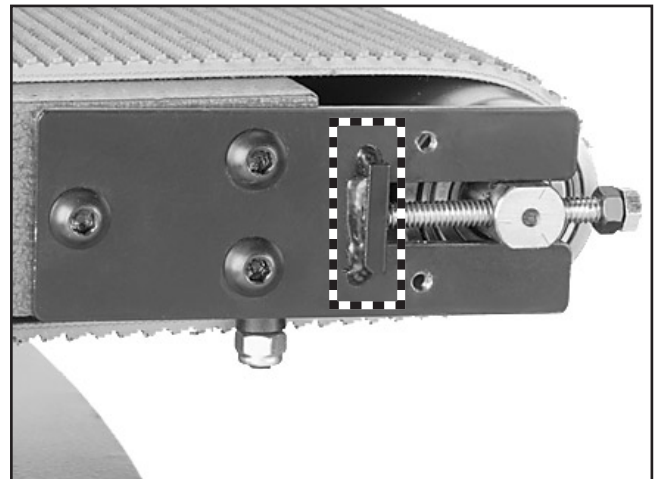
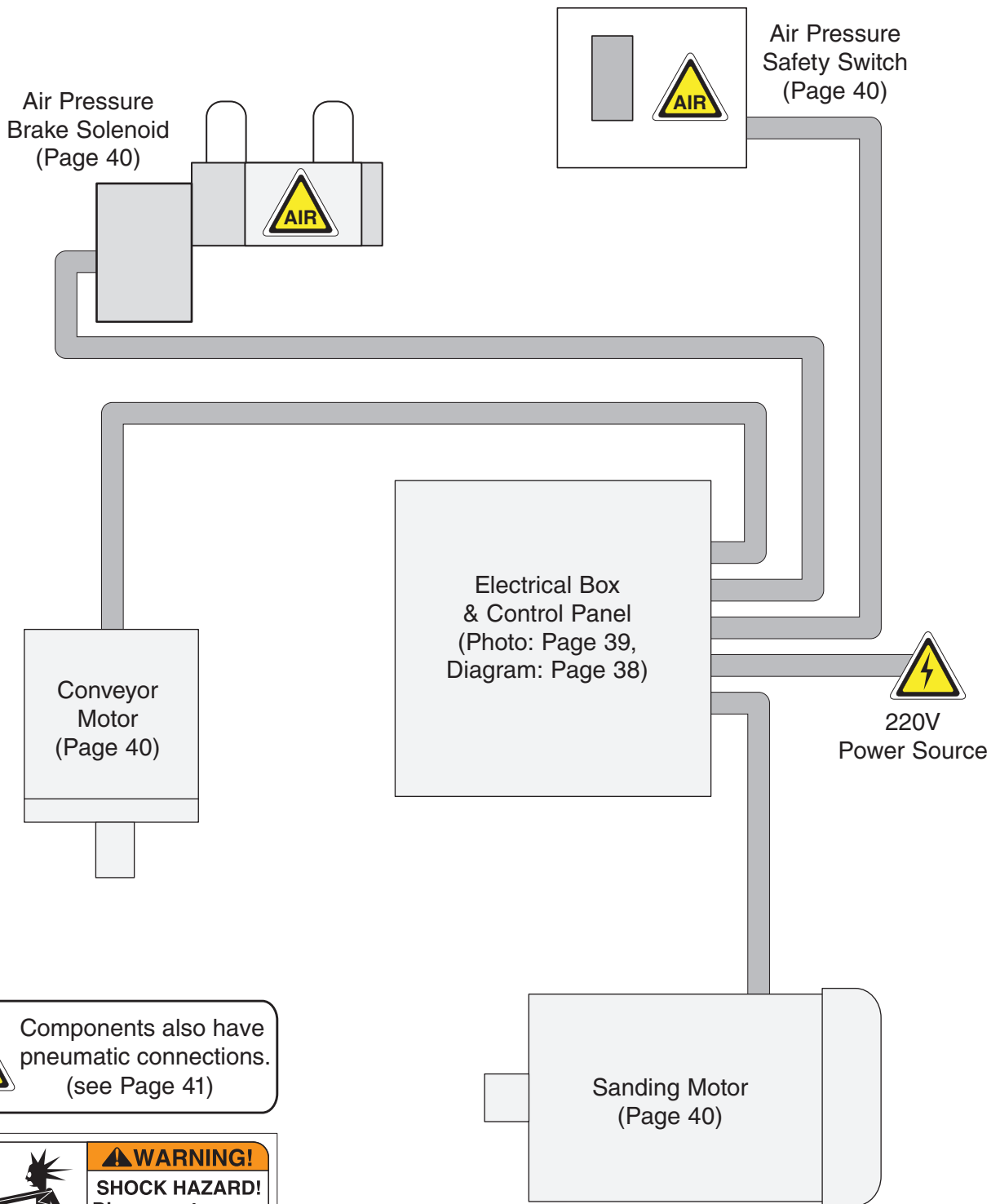



Figure 44. Conveyor roller bracket flange for the tension adjusting bolt.

- Re-tension the conveyor belt, and adjust the tracking (**Pages 30 & 31**).
- Re-adjust sanding drum and conveyor parallelism (**Page 32**).



Electrical Wiring Overview



 Components also have pneumatic connections. (see Page 41)

**WARNING!**
SHOCK HAZARD!
Disconnect power before working on wiring.



Electrical Box & Control Panel Wiring Diagram

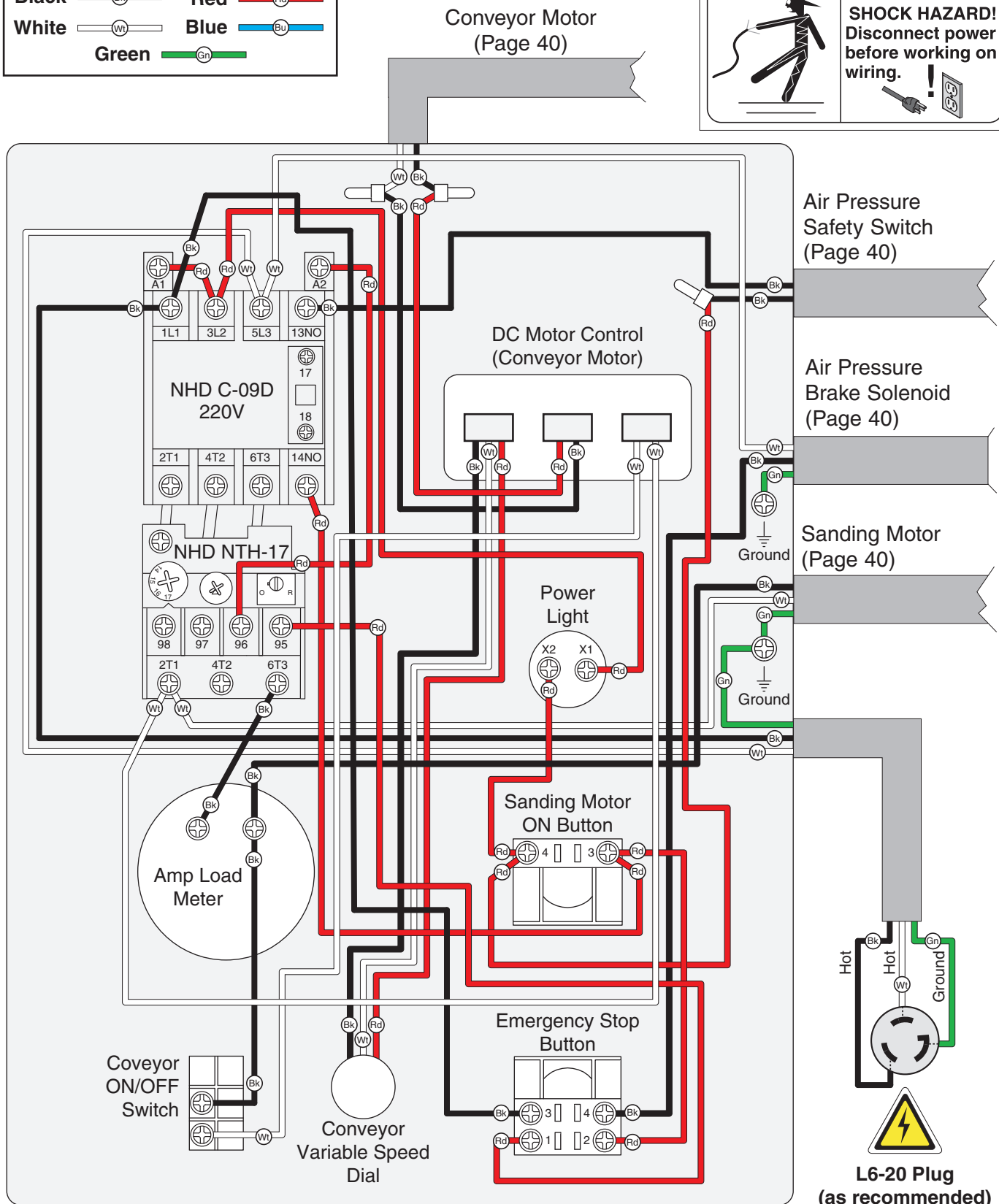
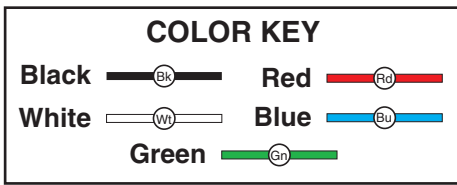

Electrical Components

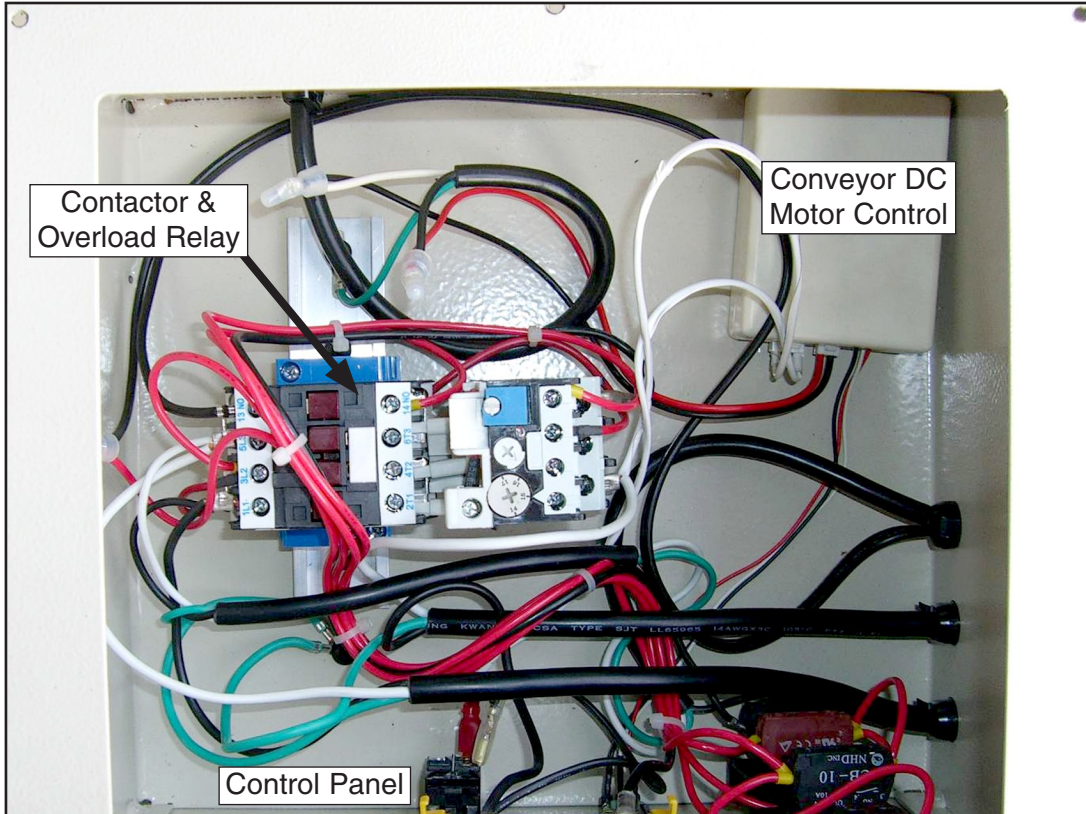

Figure 45. Electrical box wiring (Diagram: Page 38).

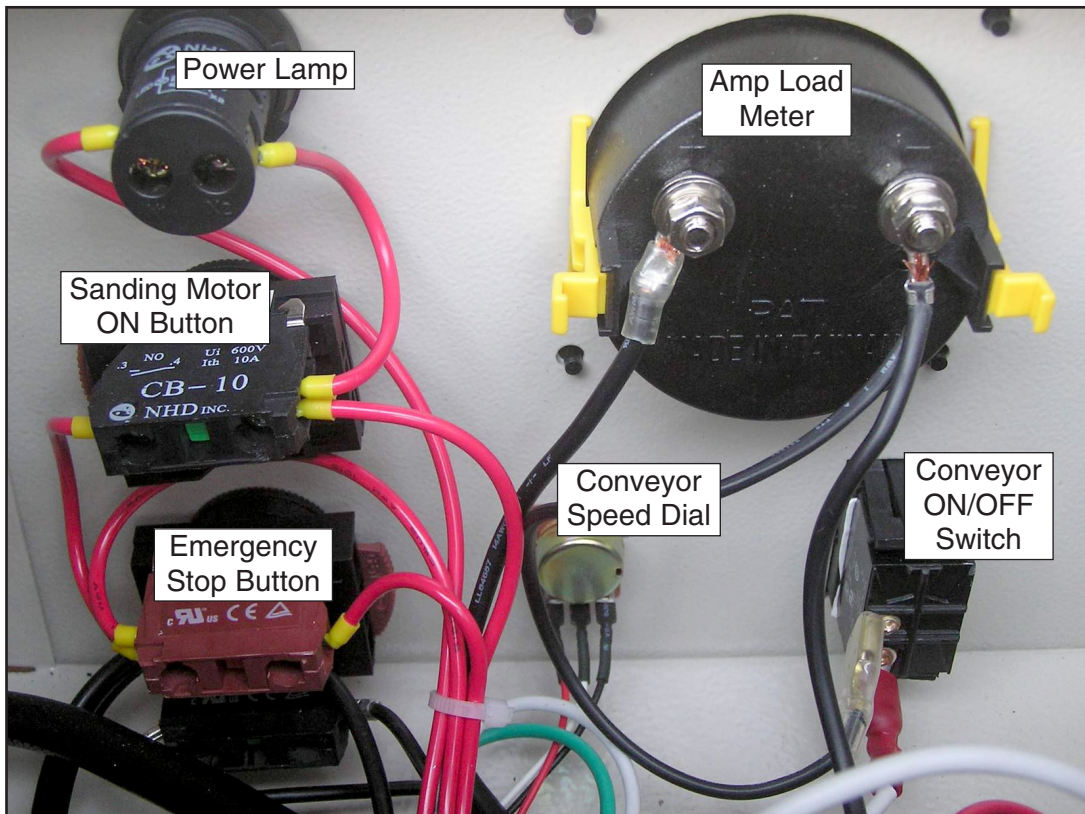

Figure 46. Control panel wiring (Diagram: Page 38).



Electrical Components

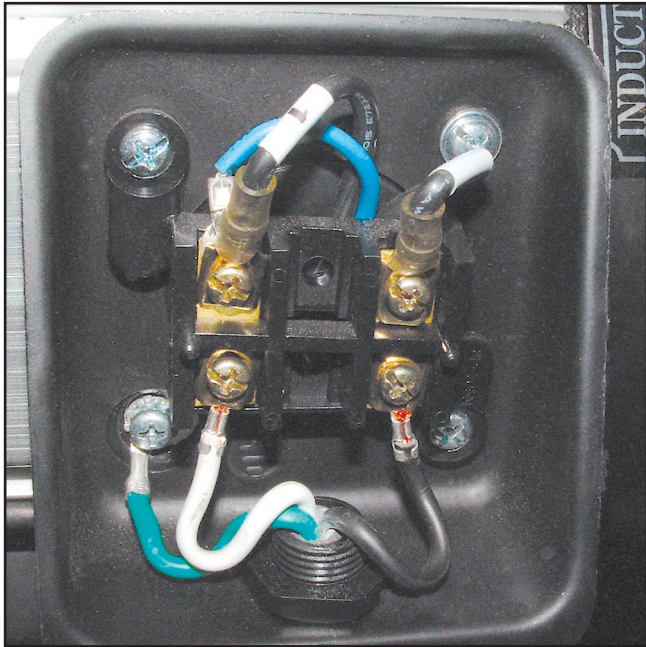

Figure 47. Sanding motor wiring.

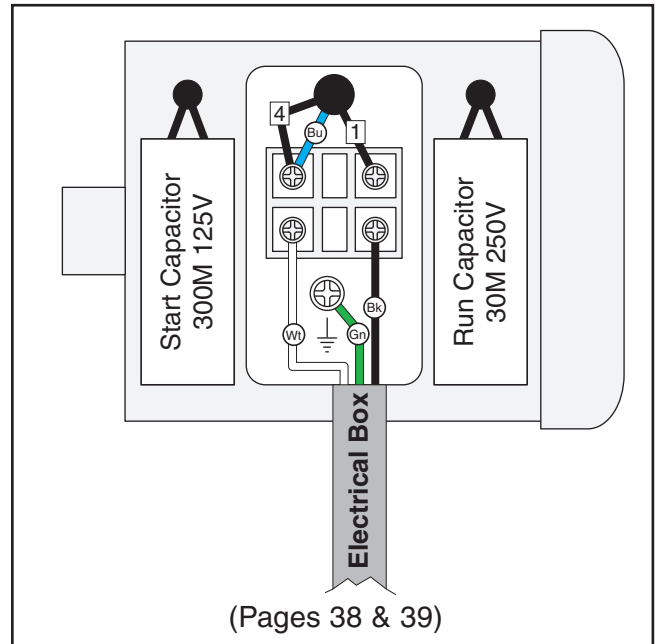

Figure 50. Sanding motor wiring diagram.



Figure 48. Conveyor motor.

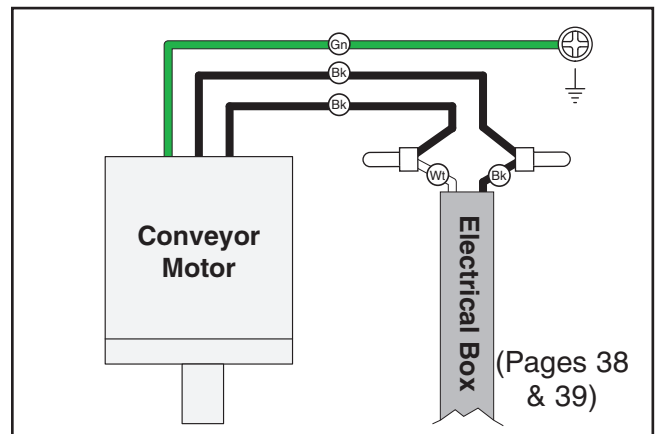

Figure 51. Conveyor motor wiring diagram.

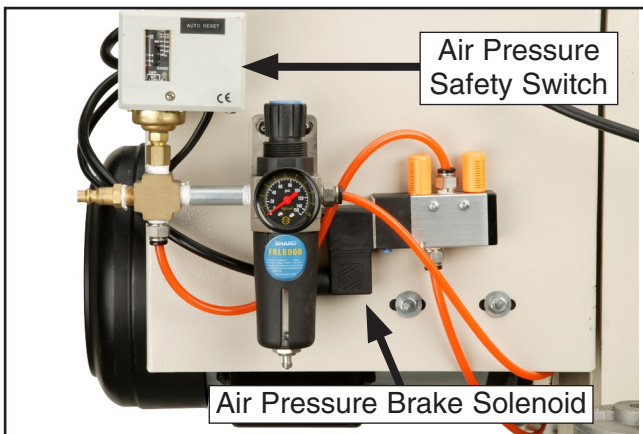

Figure 49. Air pressure safety switch and brake solenoid.

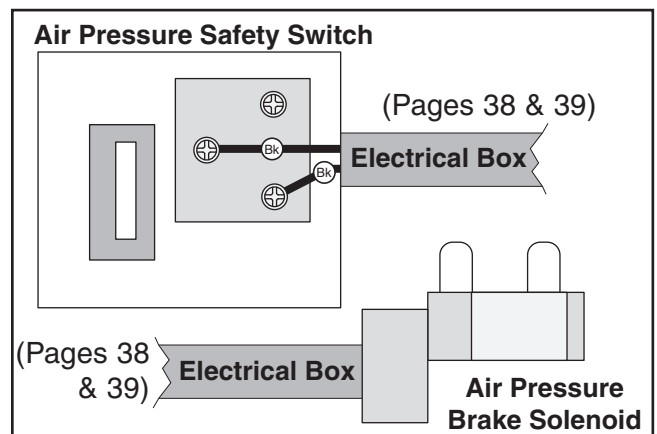
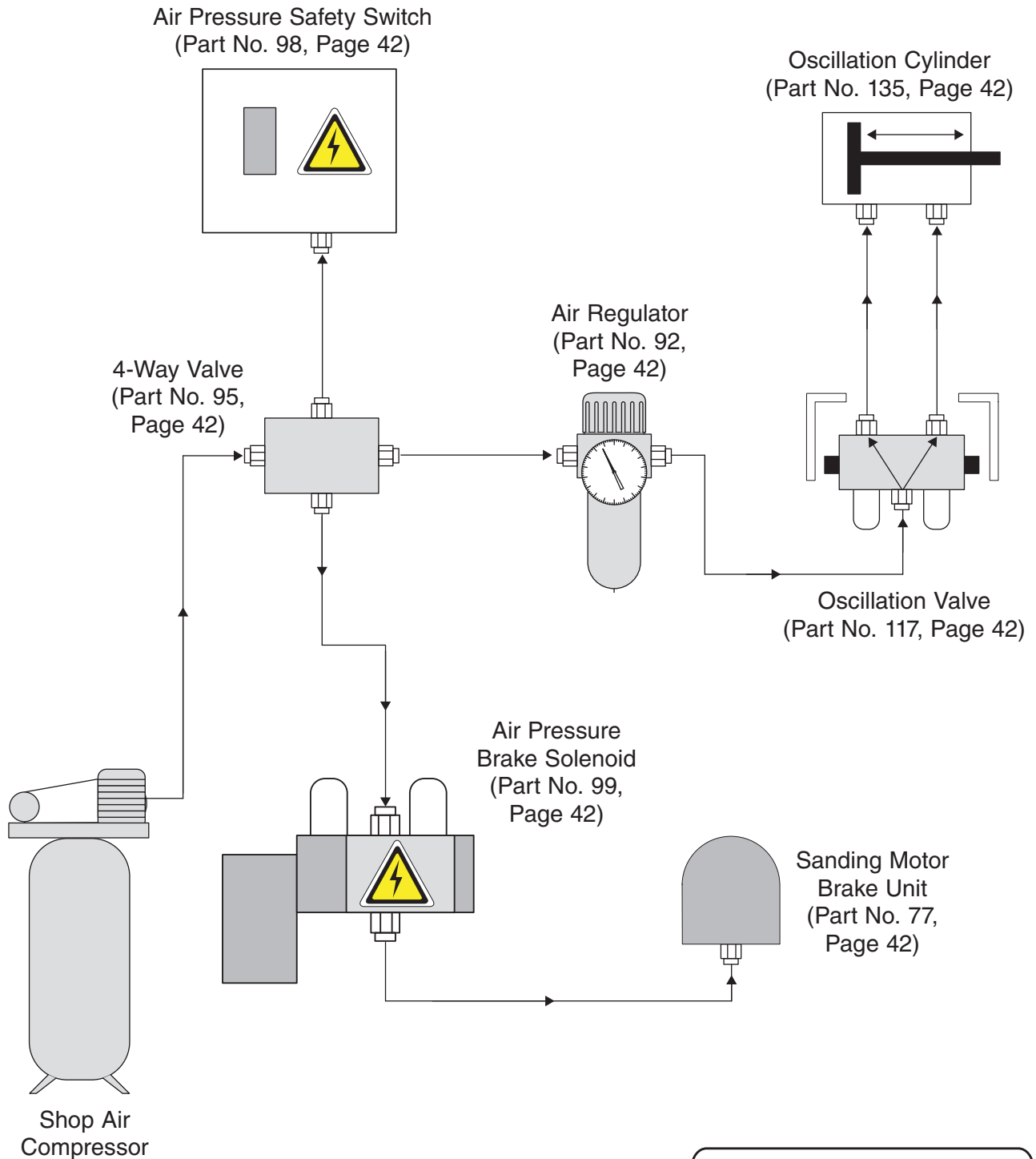



Figure 52. Air pressure safety switch and brake solenoid wiring diagram.



Air System Diagram



 Components also have electrical connections. (see Page 38)



Parts Breakdown

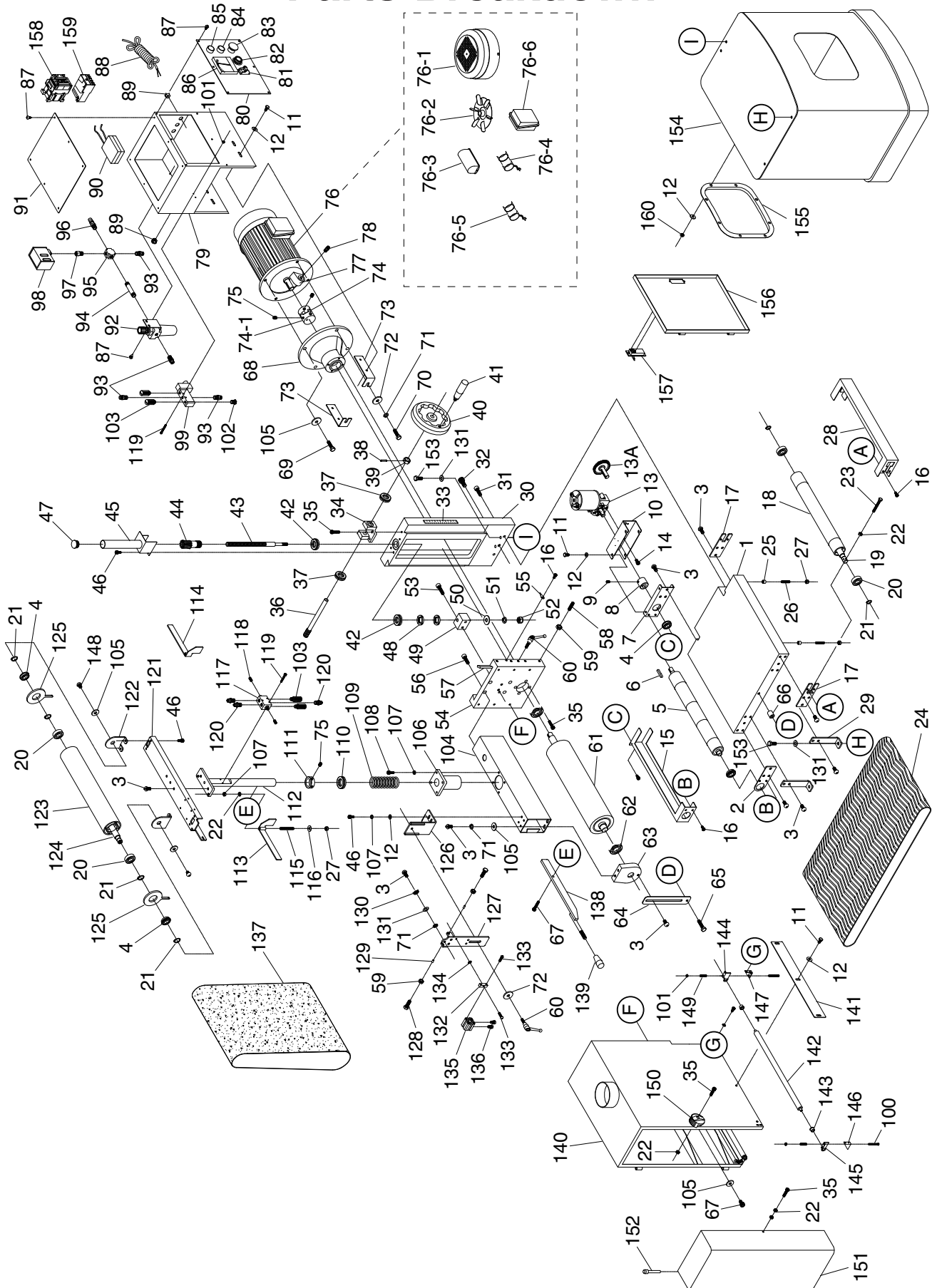

Parts List

REF	PART #	DESCRIPTION
1	P0644001	CONVEYOR TABLE
2	P0644002	CONVEYOR ROLLER BRACKET LR
3	PS16M	PHLP HD SCR M8-1.25 X 16
4	P6003	BALL BEARING 6003ZZ
5	P0644005	CONVEYOR ROLLER REAR
6	PK12M	KEY 5 X 5 X 30
7	P0644007	CONVEYOR ROLLER BRACKET RR
8	P0644008	CONNECTING BUSHING
9	PSS03	SET SCREW 1/4-20 X 3/8
10	P0644010	CONVEYOR MOTOR BRACKET
11	PB19	HEX BOLT 1/4-20 X 1/2
12	PW06	FLAT WASHER 1/4
13	P0644013	CONVEYOR MOTOR
13-1	P0644013-1	CONVEYOR MOTOR WORM
14	PSB26M	CAP SCREW M6-1 X 12
15	P0644015	CONVEYOR ROLLER GUARD R.
16	PSB02	CAP SCREW 10-24 X 3/8
17	P0644017	CONVEYOR ROLLER BRACKET F
18	P0644018	CONVEYOR ROLLER F
19	P0644019	CONVEYOR ROLLER SHAFT F
20	P6003	BALL BEARING 6003ZZ
21	PR18M	EXT RETAINING RING 17MM
22	PN05	HEX NUT 1/4-20
23	PB10	HEX BOLT 1/4-20 X 2
24	P0644024	CONVEYOR BELT
25	P0644025	SET COLLAR
26	PSS39	SET SCREW 1/4-20 X 1 1/4
27	PLN02	LOCK NUT 1/4-20
28	P0644028	CONVEYOR ROLLER GUARD F.
29	P0644029	SUPPORT LEG
30	P0644030	SUPPORT FRAME
31	PSB31M	CAP SCREW M8-1.25 X 25
32	PSB61M	CAP SCREW M10-1.5 X 20
33	P0644033	ELEVATION SCALE
34	P0644034	WORM ROD BRACKET
35	PSB06	CAP SCREW 1/4-20 X 1
36	P0644036	WORM ROD
37	P51102	THRUST BEARING 51102
38	P0644038	COMPRESSION SPRING
39	P0644039	SET NUT
40	P0644040	HAND WHEEL
41	P0644041	HANDLE
42	P51105	THRUST BEARING 51105
43	P0644043	ELEVATION LEADSCREW
44	P0644044	WORM WHEEL
45	P0644045	GEAR GUARD
46	PSB04	CAP SCREW 1/4-20 X 1/2
47	P0644047	PLUG
48	P0644048	BEARING NUT
49	P0644049	ELEVATION LEADSCREW BRACKET

REF	PART #	DESCRIPTION
50	PW04M	FLAT WASHER 10MM
51	PLW06M	LOCK WASHER 10MM
52	PLN05M	LOCK NUT M10-1.5
53	PSB11	CAP SCREW 5/16-18 X 1-1/4
54	P0644054	BELT ROLLER MOUNT LOWER
55	P0644055	POINTER
56	PSB03	CAP SCREW 5/16-18 X 1
57	P0644057	GIB
58	PSS19	SET SCREW 5/16-18 X 1 1/4
59	PN02	HEX NUT 5/16-18
60	P0644060	LOCK HANDLE
61	P0644061	SANDING DRUM
62	P6205	BALL BEARING 6205ZZ
63	P0644063	BEARING HOUSING
64	P0644064	AUXILIARY SUPPORT PLATE
65	PB20M	HEX BOLT M8-1.25 X 35
66	P0644066	SPACER
67	PSB30	CAP SCREW 5/16-18 X 1/2
68	P0644068	MOTOR MOUNT
69	PB03	HEX BOLT 5/16-18 X 1
70	PB12	HEX BOLT 5/16-18 X 1-1/4
71	PLW01	LOCK WASHER 5/16
72	PW07	FLAT WASHER 5/16
73	P0644073	SWITCH BOX SUPPORT BRACKET
74	P0644074	COUPLER
74-1	P0644074-1	COUPLER PAD
75	PSS02	SET SCREW 5/16-18 X 3/8
76	P0644076	MOTOR 220V 1-PH
76-1	P0644076-1	MOTOR FAN COVER
76-2	P0644076-2	MOTOR FAN
76-3	P0644076-3	CAPACITOR COVER
76-4	P0644076-4	R CAPACITOR 50M 250V 1-3/8 X 3-1/8
76-5	P0644076-5	S CAPACITOR 400M 125V 1-3/8 X 3
76-6	P0644076-6	MOTOR JUNCTION BOX
77	P0644077	BRAKE UNIT
78	P0644078	STRAIN RELIEF
79	P0644079	SWITCH BOX
80	P0644080	SWITCH PLATE
81	P0644081	POWER SWITCH
82	P0644082	CONVEYOR SPEED CONTROL
83	P0644083	EMERGENCY STOP BUTTON
84	P0644084	SANDING MOTOR BUTTON
85	P0644085	POWER INDICATION LAMP
86	P0644086	AMPERAGE METER
87	PHTEK6	TAP SCREW #10 X 3/8
88	P0644088	POWER CORD
89	P0644089	STRAIN RELIEF
90	P0644090	DC MOTOR SPEED CONTROLLER
91	P0644091	SWITCH BOX UPPER COVER
92	P0644092	AIR FILTER



Parts List

REF PART #	DESCRIPTION
93	P0644093 TUBE CONNECTOR
94	P0644094 CONNECTING TUBE
95	P0644095 4-WAY VALVE
96	P0644096 AIR INLET 1/4 NPT
97	P0644097 CONNECTOR
98	P0644098 AIR PRESSURE SAFETY SWITCH
99	P0644099 AIR PRESSURE BRAKE SOLENOID
100	PS01 PHLP HD SCR 10-24 x 1-1/2
101	PLN04 LOCK NUT 10-24
102	P0644102 AIR PLUG
103	P0644103 SILENCER
104	P0644104 SUPPORT ARM
105	PW01M FLAT WASHER 8MM
106	P0644106 ELEVATION ROD GUIDE
107	PLW02 LOCK WASHER 1/4
108	PSB01 CAP SCREW 1/4-20 X 5/8
109	P0644109 COMPRESSION SPRING
110	P51106 THRUST BEARING 51106
111	P0644111 LOCKING COLLAR
112	P0644112 SANDING BELT ELEVATION ROD
113	P0644113 CRANK LEFT
114	P0644114 CRANK RIGHT
115	PSS50 SET SCREW 1/4-20 X 2
116	PW06 FLAT WASHER 1/4
117	P0644117 VALVE
118	P0644118 COMPRESSION SPRING
119	PSB21M CAP SCREW M4-.7 X 30
120	P0644120 PIPE JOINT
121	P0644121 ROLLER SUPPORT FRAME UPPER
122	P0644122 ROLLER BRACKET UPPER
123	P0644123 SANDING ROLLER UPPER
124	P0644124 SANDING ROLLER SHAFT UPPER
125	P0644125 OSCILLATION SENSOR PLATE
126	P0644126 CYLINDER SUPPORT BRACKET

REF PART #	DESCRIPTION
127	P0644127 CYLINDER SUPPORT PLATE
128	P0644128 SPECIAL SCREW
129	P0644129 BUFFER PAD
130	P608 BALL BEARING 608ZZ
131	PW01M FLAT WASHER 8MM
132	P0644132 CYLINDER BRACKET
133	PS06M PHLP HD SCR M5-.8 X 20
134	P0644134 GEAR WASHER 5MM
135	P0644135 CYLINDER
136	P0644136 PIPE JOINT
137	P0644137 SANDING BELT
138	P0644138 LEVER
139	P0644139 HANDLE
140	P0644140 SANDING BELT GUARD
141	P0644141 DEPTH OF CUT SAFETY PLATE
142	P0644142 PRESSURE ROLLER
143	P0644143 PRESSURE ROLLER BUSHING
144	P0644144 PRESSURE ROLLER BRACKET R
145	P0644145 PRESSURE ROLLER BRACKET L
146	P0644146 PRESSURE ROLLER SUPPORT BRACKET L
147	P0644147 PRESSURE ROLLER SUPPORT BRACKET R.
148	PS76M PHLP HD SCR M8-1.25 X 12
149	P0644149 COIL SPRING
150	P0644150 SIDE COVER LOCK KNOB
151	P0644151 SIDE COVER
153	PB07M HEX BOLT M8-1.25 X 25
154	P0644154 CABINET
155	P0644155 FRONT FACE PLATE
156	P0644156 DOOR
157	P0644157 DOOR LOCK
158	P0644158 CONTACTOR NHD C-090 220V
159	P0644159 OL RELAY NHD NTH NTH-17 14-17A
160	PN01M HEX NUT M6-1



Label Placement & List

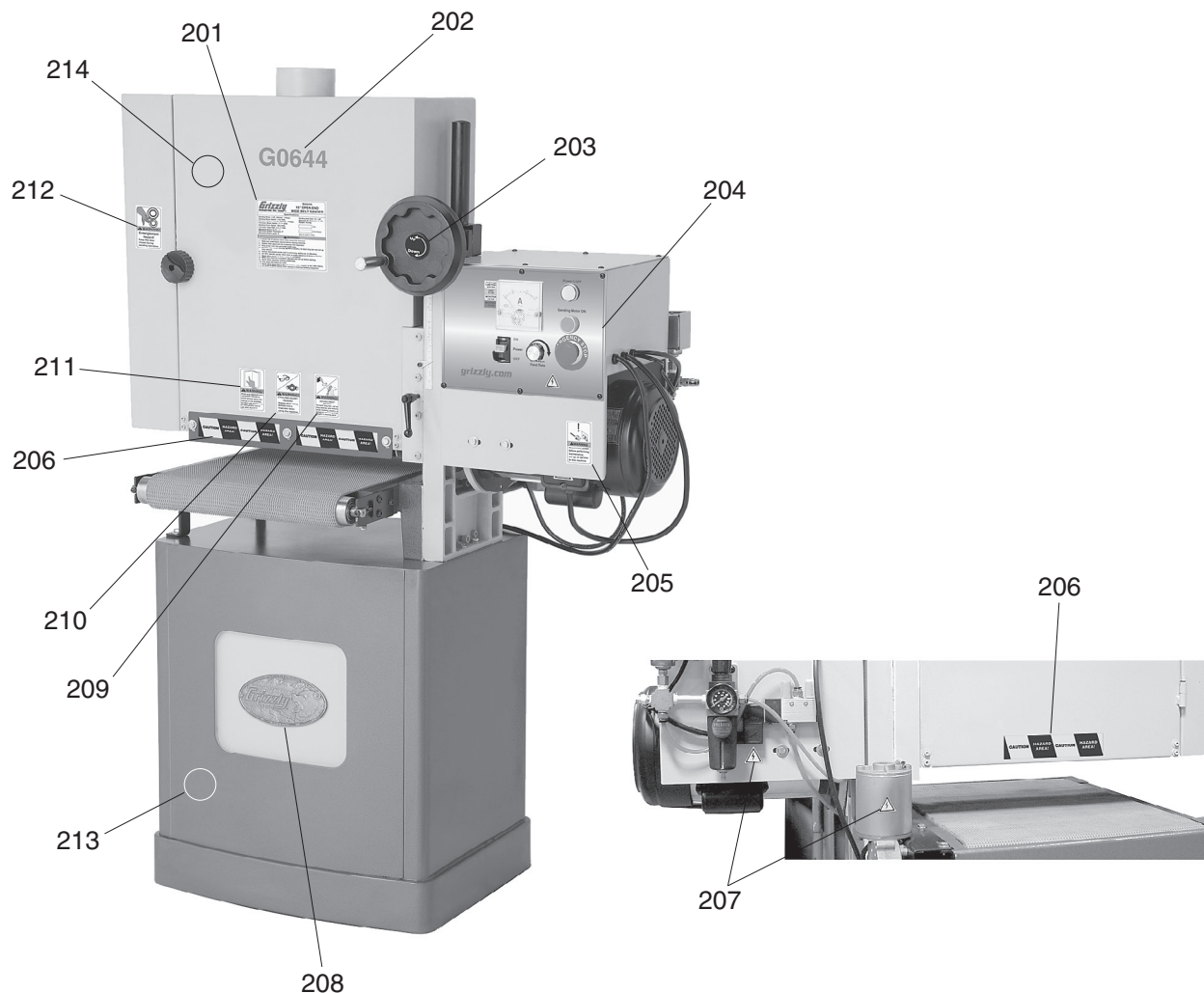

REF	PART #	DESCRIPTION
201	P0644201	MACHINE ID LABEL
202	P0644202	MODEL NUMBER LABEL
203	P0644203	ELEVATION HANDWHEEL LABEL
204	P0644204	CONTROL PANEL LABEL
205	P0644205	DISCONNECT WARNING LABEL VERT
206	P0644206	HAZARD AREA LABEL
207	PLABEL-14	ELECTRICITY LABEL

REF	PART #	DESCRIPTION
208	P0644208	GRIZZLY NAMEPLATE 9-1/4" X 4-1/2"
209	P0644209	ENTANGLEMENT HAZARD LABEL VERT
210	P0644210	EYE/LUNG HAZARD LABEL VERT
211	P0644211	READ MANUAL LABEL VERT
212	P0644212	HAND INJURY LABEL VERT
213	P0644213	GRIZZLY GREEN TOUCH UP PAINT
214	P0644214	GRIZZLY PUTTY TOUCH UP PAINT

WARNING

Safety labels warn about machine hazards and ways to prevent injury. The owner of this machine **MUST** maintain the original location and readability of the labels on the machine. If any label is removed or becomes unreadable, **REPLACE** that label before using the machine again. Contact Grizzly at (800) 523-4777 or www.grizzly.com to order new labels.





WARRANTY CARD

Name _____

Street _____

City _____ State _____ Zip _____

Phone # _____ Email _____ Invoice # _____

Model # _____ Order # _____ Serial # _____

The following information is given on a voluntary basis. It will be used for marketing purposes to help us develop better products and services. **Of course, all information is strictly confidential.**

1. How did you learn about us?

- Advertisement
- Card Deck
- Friend
- Website
- Catalog
- Other:

2. Which of the following magazines do you subscribe to?

- | | | |
|---|--|---|
| <input type="checkbox"/> Cabinet Maker | <input type="checkbox"/> Popular Mechanics | <input type="checkbox"/> Today's Homeowner |
| <input type="checkbox"/> Family Handyman | <input type="checkbox"/> Popular Science | <input type="checkbox"/> Wood |
| <input type="checkbox"/> Hand Loader | <input type="checkbox"/> Popular Woodworking | <input type="checkbox"/> Wooden Boat |
| <input type="checkbox"/> Handy | <input type="checkbox"/> Practical Homeowner | <input type="checkbox"/> Woodshop News |
| <input type="checkbox"/> Home Shop Machinist | <input type="checkbox"/> Precision Shooter | <input type="checkbox"/> Woodsmith |
| <input type="checkbox"/> Journal of Light Cont. | <input type="checkbox"/> Projects in Metal | <input type="checkbox"/> Woodwork |
| <input type="checkbox"/> Live Steam | <input type="checkbox"/> RC Modeler | <input type="checkbox"/> Woodworker West |
| <input type="checkbox"/> Model Airplane News | <input type="checkbox"/> Rifle | <input type="checkbox"/> Woodworker's Journal |
| <input type="checkbox"/> Modeltec | <input type="checkbox"/> Shop Notes | <input type="checkbox"/> Other: |
| <input type="checkbox"/> Old House Journal | <input type="checkbox"/> Shotgun News | |

3. What is your annual household income?

- \$20,000-\$29,000
- \$30,000-\$39,000
- \$40,000-\$49,000
- \$50,000-\$59,000
- \$60,000-\$69,000
- \$70,000+

4. What is your age group?

- 20-29
- 30-39
- 40-49
- 50-59
- 60-69
- 70+

5. How long have you been a woodworker/metalworker?

- 0-2 Years
- 2-8 Years
- 8-20 Years
- 20+ Years

6. How many of your machines or tools are Grizzly?

- 0-2
- 3-5
- 6-9
- 10+

7. Do you think your machine represents a good value? Yes No

8. Would you recommend Grizzly Industrial to a friend? Yes No

9. Would you allow us to use your name as a reference for Grizzly customers in your area?
Note: We never use names more than 3 times. Yes No

10. Comments: _____

CUT ALONG DOTTED LINE

FOLD ALONG DOTTED LINE



Place Stamp Here



GRIZZLY INDUSTRIAL, INC.
P.O. BOX 2069
BELLINGHAM, WA 98227-2069



FOLD ALONG DOTTED LINE

Send a Grizzly Catalog to a friend:

Name _____
Street _____
City _____ State _____ Zip _____

TAPE ALONG EDGES--PLEASE DO NOT STAPLE

WARRANTY AND RETURNS

Grizzly Industrial, Inc. warrants every product it sells for a period of **1 year** to the original purchaser from the date of purchase. This warranty does not apply to defects due directly or indirectly to misuse, abuse, negligence, accidents, repairs or alterations or lack of maintenance. This is Grizzly's sole written warranty and any and all warranties that may be implied by law, including any merchantability or fitness, for any particular purpose, are hereby limited to the duration of this written warranty. We do not warrant or represent that the merchandise complies with the provisions of any law or acts unless the manufacturer so warrants. In no event shall Grizzly's liability under this warranty exceed the purchase price paid for the product and any legal actions brought against Grizzly shall be tried in the State of Washington, County of Whatcom.

We shall in no event be liable for death, injuries to persons or property or for incidental, contingent, special, or consequential damages arising from the use of our products.

To take advantage of this warranty, contact us by mail or phone and give us all the details. We will then issue you a "Return Number," which must be clearly posted on the outside as well as the inside of the carton. We will not accept any item back without this number. Proof of purchase must accompany the merchandise.

The manufacturers reserve the right to change specifications at any time because they constantly strive to achieve better quality equipment. We make every effort to ensure that our products meet high quality and durability standards and we hope you never need to use this warranty.

Please feel free to write or call us if you have any questions about the machine or the manual.

Thank you again for your business and continued support. We hope to serve you again soon.

grizzly.com

TOOL WEBSITE

Buy Direct and Save with Grizzly® – Trusted, Proven and a Great Value!

*Visit Our Website Today And Discover
Why Grizzly® Is The Industry Leader!*

- SECURE ORDERING
- ORDERS SHIPPED WITHIN 24 HOURS
- E-MAIL RESPONSE WITHIN ONE HOUR

-OR-

Call Today For A **FREE**
Full Color Catalog

1-800-523-4777

